

# AN01507

## RHF76-052AM Hardware Design Guide

---

V1.3

### Document information

Info	Content
<b>Keywords</b>	<i>RisingHF, RHF76-052, RHF76-052AM, UART, Modem, Upgrade, Hardware, Reference design</i>
<b>Abstract</b>	This document is a description for HW of RHF76-052AM/AN UART modem.

## Content

Content.....	2
Figures .....	3
Tables.....	4
1 Introduction.....	1
2 GPIO Definition.....	1
2.1 Pin definition of Module .....	1
2.2 Internal connection (RF radio SX1276/8 and MCU STM32L05x).....	3
3 Hardware Design Reference.....	4
Revision.....	6

## Figures

Figure 2-1 Internal connection between RF radio and MCU.....	3
Figure 3-1 RHF76-052AM Reference Design .....	4

## Tables

Table 2-1 GPIO description ..... 1

# 1 Introduction

RisingHF™ LoRaWAN™ UART modem RHF76-052AM are LoRaWAN compatible device, supports LoRaWAN communication. These two modems are based on the RHF76-052 module and an embedded LoRaWAN stack. Customer could use a host MCU to control this modem with simple AT command. The advanced and simple command interface offers rapid time to market.

This document is targeted to help customer to set their hardware platform quickly with RHF76-052AM/AN UART modem. The only difference between the two modems is the boot loader interface. RHF76-052AM use UART bootloader for firmware upgrade.

**RHF76-052AM** — UART AT command, UART bootloader

## 2 GPIO Definition

### 2.1 Pin definition of Module

Table 2-1 GPIO description

Number	Name	Type	Description and application
1	VCC	-	Supply voltage for the module
2	GND	-	Ground
3	PA8	I/O	GPIO_PA8 <sup>(2)</sup>
4	PA9	I/O	GPIO_PA9; UART1_TX of Modem for Firmware upgrade(RHF76-052AM) (115200,8,n,1)
5	PA10	I/O	GPIO_PA10; UART1_RX of Modem for Firmware upgrade(RHF76-052AM) (115200,8,n,1)
6	NSS	I/O	GPIO_PB12
7	SCK	I/O	GPIO_PB13
8	MISO	I/O	GPIO_PB14
9	MOSI	I/O	GPIO_PB15
10	USART1_CTS	I/O	USART1_CTS <sup>(1)</sup> from MCU; GPIO_PA11;
11	USART1_RTS	I/O	USART1_RTS <sup>(1)</sup> from MCU; GPIO_PA12;
12	SWDIO	I/O	SWDIO of SWIM for program download;
13	SWCLK	I/O	SWCLK of SWIM for program download;
14	PA15	I/O	Boot_EN (GPIO_PA15), Low to enable bootloader during power up for FW upgrade.
15	PB3	I/O	GPIO_PB3
16	PB4	I/O	Status LED (GPIO_PB4) trigger, connect to an external LED to show status of LoRaWAN processing

Number	Name	Type	Description and application
17	NC	-	Connected to Ground
18	NC	-	Connected to Ground
19	NC	-	Connected to Ground
20	PA3/ADC3	I/O	GPIO_PA3
21	PB5	I/O	Status LED (GPIO_PB5) trigger, connect to an external LED, Reserved
22	USART1_TX	I/O	USART1_TX of Modem, connect to RXD of Host MCU
23	USART1_RX	I/O	USART1_RX of Modem, connect to TXD of Host MCU
24	I2C_SCL	I/O	GPIO_PB8
25	I2C_SDA	I/O	GPIO_PB9
26	PC13/Wkup2	I/O	GPIO_PC13; High or Low band select (HF:0, LF:1)
27	NRST	I	Reset trigger input of Modem
28	PA0/AD0	I/O	GPIO_PA0; High or Low band select (HF:1, LF:0)
29	GND	-	Ground
30	RFIO_HF	-	RF input/output in high band, i.e. 868MHz/915MHz
31	GND	-	Ground
32	RFIO_LF	-	RF input/output in low band, i.e. 434MHz/470MHz
33	GND	-	Ground

Note: (1) Optional handshake lines are supported in future firmware releases.  
 (2) GPIO couldn't be controlled by Host MCU by UART in current version.

## 2.2 Internal connection (RF radio SX1276/8 and MCU STM32L05x)

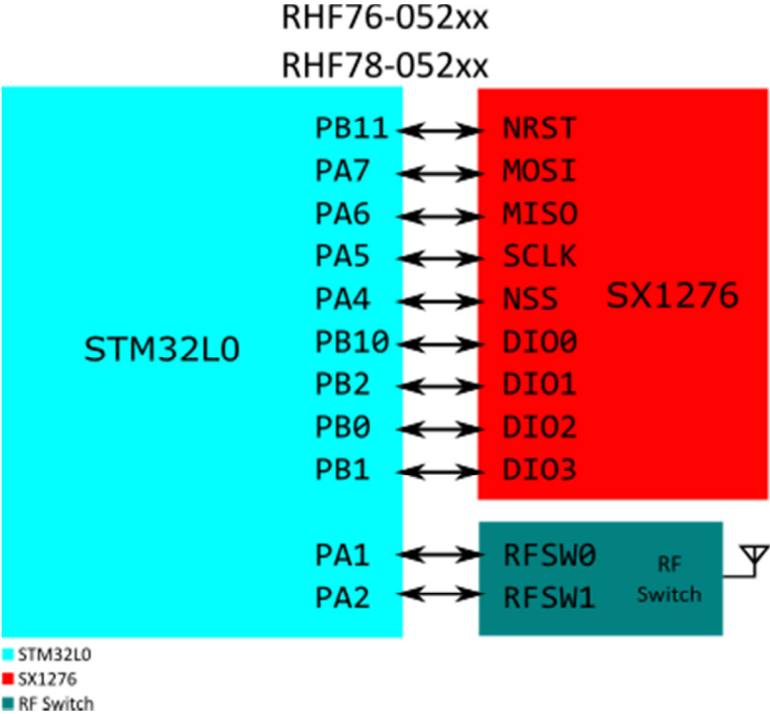

Figure 2-1 Internal connection between RF radio and MCU

### 3 Hardware Design Reference

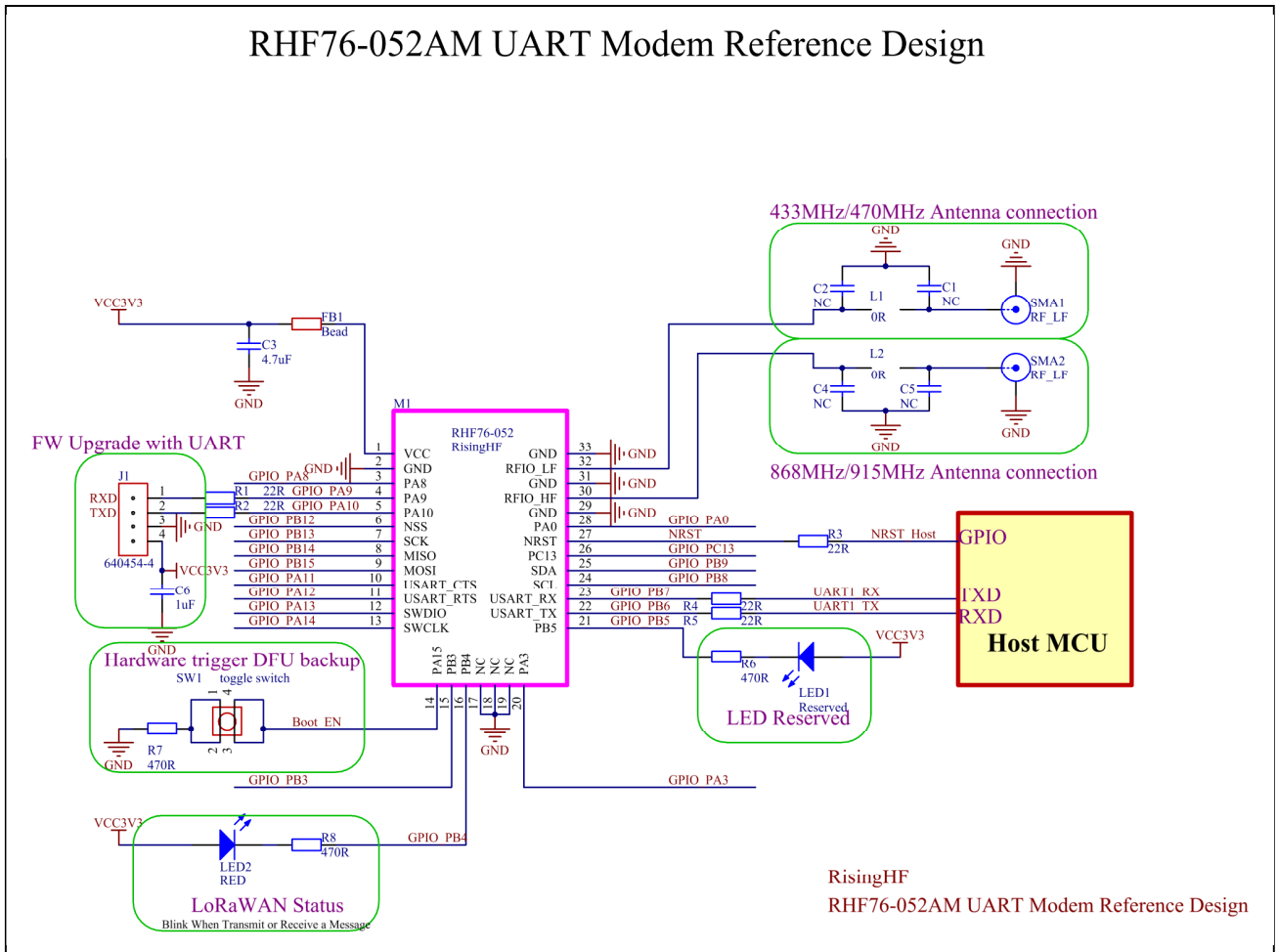

Figure 3-1 RHF76-052AM Reference Design



### Hardware design description:

- 1) VCC operation range: +1.8V to +3.6V
- 2) Pin22 and Pin 23 of the Modem would be used as UART port, please connect to Host MCU. Pin22 should be connected to RXD of Host MCU, and Pin23 should be connected to TXD of Host MCU.
- 3) **RHF76-52AM**: Pin4 and Pin5 of the Modem would be used as FW upgrade port based on UART connection. Pin4 should be connected to RXD of Host, and Pin5 should be connected to TXD of Host.
- 4) Pin14 (GPIO\_PA15) would be used to enable the DFU mode for FW upgrade. Please connect it to a toggle switch to achieve DFU enable function via a hardware way.  
  
Note: Customer could also use a SW way with AT command to access into DFU mode.
- 5) Pin16 would be used to show LoRaWAN processing status. Please connect this pin to a LED if need.  
  
This LED would blink when transmit or receive a message in LoRaWAN mode.
- 6) Pin21 would be used to be reserved for LED connection.
- 7) RHF76-052AM UART modem support both low band (434MHz/470MHz) and high band (868MHz/915MHz). When use an internal antenna with mismatch impedance, a  $\pi$  topology for antenna matching is strongly suggested.

## Revision

- V1.3 2017-07-28
  - +Remove RHF76-052AN, add internal pin connection information.
- V1.2 2015-09-12
  - +Add RHF76-052AN
- V1.1 2015-09-02
  - + Improve GPIO connection in the reference design
- V1.0 2015-07-02
  - + Draft

### **Please Read Carefully:**

Information in this document is provided solely in connection with RisingHF products. RisingHF reserve the right to make changes, corrections, modifications or improvements, to this document, and the products and services described herein at any time, without notice.

All RisingHF products are sold pursuant to RisingHF's terms and conditions of sale.

Purchasers are solely responsible for the choice, selection and use of the RisingHF products and services described herein, and RisingHF assumes no liability whatsoever relating to the choice, selection or use of the RisingHF products and services described herein.

No license, express or implied, by estoppel or otherwise, to any intellectual property rights is granted under this document. If any part of this document refers to any third party products or services it shall not be deemed a license grant by RisingHF for the use of such third party products or services, or any intellectual property contained therein or considered as a warranty covering the use in any manner whatsoever of such third party products or services or any intellectual property contained therein.

UNLESS OTHERWISE SET FORTH IN RISINGHF'S TERMS AND CONDITIONS OF SALE RisingHF DISCLAIMS ANY EXPRESS OR IMPLIED WARRANTY WITH RESPECT TO THE USE AND/OR SALE OF RisingHF PRODUCTS INCLUDING WITHOUT LIMITATION IMPLIED WARRANTIES OF MERCHANTABILITY, FITNESS FOR A PARTICULAR PURPOSE (AND THEIR EQUIVALENTS UNDER THE LAWS OF ANY JURISDICTION), OR INFRINGEMENT OF ANY PATENT, COPYRIGHT OR OTHER INTELLECTUAL PROPERTY RIGHT.

RISINGHF PRODUCTS ARE NOT DESIGNED OR AUTHORIZED FOR USE IN: (A) SAFETY CRITICAL APPLICATIONS SUCH AS LIFE SUPPORTING, ACTIVE IMPLANTED DEVICES OR SYSTEMS WITH PRODUCT FUNCTIONAL SAFETY REQUIREMENTS; (B) AERONAUTIC APPLICATIONS; (C) AUTOMOTIVE APPLICATIONS OR ENVIRONMENTS, AND/OR (D) AEROSPACE APPLICATIONS OR ENVIRONMENTS. WHERE RISINGHF PRODUCTS ARE NOT DESIGNED FOR SUCH USE, THE PURCHASER SHALL USE PRODUCTS AT PURCHASER'S SOLE RISK, EVEN IF RISINGHF HAS BEEN INFORMED IN WRITING OF SUCH USAGE, UNLESS A PRODUCT IS EXPRESSLY DESIGNATED BY RISINGHF AS BEING INTENDED FOR "AUTOMOTIVE, AUTOMOTIVE SAFETY OR MEDICAL" INDUSTRY DOMAINS ACCORDING TO RISINGHF PRODUCT DESIGN SPECIFICATIONS. PRODUCTS FORMALLY ESCC, QML OR JAN QUALIFIED ARE DEEMED SUITABLE FOR USE IN AEROSPACE BY THE CORRESPONDING GOVERNMENTAL AGENCY.

Resale of RisingHF products with provisions different from the statements and/or technical features set forth in this document shall immediately void any warranty granted by RisingHF for the RisingHF product or service described herein and shall not create or extend in any manner whatsoever, any liability of RisingHF.

RisingHF and the RisingHF logo are trademarks or registered trademarks of RisingHF in various countries.

Information in this document supersedes and replaces all information previously supplied.

The RisingHF logo is a registered trademark of RisingHF. All other names are the property of their respective owners.

© 2015 RISINGHF - All rights reserved

<http://www.risinghf.com>