

## DS01862

### RHF0M062 Datasheet

---

V3.0

#### Document information

Info	Content
<b>Keywords</b>	<i>RisingHF, LoRaWAN, RHF0M062, Small size AT command</i>
<b>Abstract</b>	This document is the RHF0M062 Datasheet

## contents

contents.....	1
Figure.....	2
Table.....	3
1 Description.....	6
1.1 Schematic diagram.....	6
1.2 Pin definition.....	6
2 Electrical Characteristics.....	7
2.1 Absolute Maximum Ratings.....	7
2.2 Operating Range.....	7
2.3 Module Specifications.....	8
3 Typical Performance.....	9
3.1 RHF0M062-LF22 measurement.....	9
3.2 RHF0M062-HF22 measurement.....	12
4 Application Information.....	15
4.1 Package Information.....	15
4.2 Interface of Module.....	16
4.3 Reference design with RHF0M062 Module.....	16
5 Application in LoRaWAN.....	16
5.1 LoRaWAN.....	16
5.2 LoRaWAN sensor with RHF0M062.....	17
6 Ordering information.....	17
Revision.....	18

## Figure

Figure 1	RHF0M062 Module Outline.....	4
Figure 2	RHF0M062 schematic diagram.....	6
Figure 3	Pin definition of RHF0M062.....	6
Figure 4	TXOP vs Supply voltage (470MHz) .....	9
Figure 5	Sensitivity (SF12,125kHz) vs Supply voltage (470MHz) .....	9
Figure 6	TXOP vs Temperature.....	10
Figure 7	Sensitivity (SF12,125kHz) vs temperature.....	10
Figure 8	Harmonics measurement @Frf=470MHz, TXOP=21dBm (470MHz) .....	11
Figure 9	TXOP vs Supply voltage (868/915MHz) .....	12
Figure 10	Sensitivity (SF12,125kHz) vs Supply voltage (868/915MHz) .....	12
Figure 11	TXOP vs Temperature (868/915MHz) .....	13
Figure 12	Sensitivity (SF12,125kHz) vs temperature.....	13
Figure 13	Harmonics measurement @Frf=868MHz, TXOP=22dBm (868MHz) .....	14
Figure 14	RHF0M062 package outline drawing.....	15
Figure 15	Recommended land pattern.....	15
Figure 16	Reference design with RHF0M062.....	16
Figure 17	LoRaWAN sensor with RHF0M062 .....	17

## Table

Table 1 Pin description.....	7
Table 2 Absolute Maximum Ratings .....	7
Table 3 Operating Range.....	7
Table 4 Module Specifications.....	8
Table 5 Ordering information.....	17

### Ultra-low power and small size LoRaWAN Module RHF0M062

#### Description

RHF0M062 is a low-cost, ultra-low power, ultra-small LoRaWAN module designed by RisingHF. The module uses low power and high-performance LoRa chip SX1262 and Cypress ultra-low power MCU.

The module's target applications are wireless sensor networks and other IoT devices, especially battery powered which requires low power and long distance.

#### Applications

The RHF0M062 LoRaWAN module is ideal for long-range, ultra-low-power applications such as wireless meter reading, sensor networks and other IoT applications.

#### Features

- ◆ Low power consumption: down to 2.7uA sleep current (WOR mode);
- ◆ low cost;

- ◆ SX1262 and cost-effective MCU;
- ◆ Small size: 14mm \* 15mm \*3.15mm with 18 pins SMT
- ◆ High performance:  
RHF0M062-LF22:  
TXOP=21dBm@470MHz  
RHF0M062-HF22:  
TXOP=22dBm@868MHz/915MHz  
160dB link budget, suitable for long range use cases
- ◆ User-friendly interface  
USART;  
I2C;  
SWD;  
ADC;
- ◆ Support global LoRaWAN protocol  
EU868;  
US915 and US915 Hybrid;  
CN779;  
AU915;  
CN470 and CN470 Prequel;  
AS923;  
KR920;  
IN865;

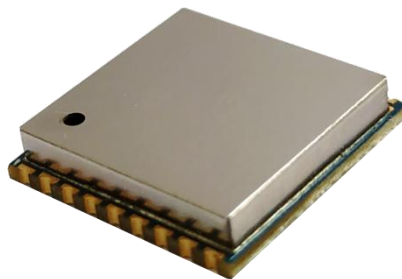

Figure 1 RHF0M062 Module Outline

This product specification describe the performance and functions of the RHF0M062 module in details. Please contact RisingHF for the latest FW, product updates or errata.

## 1 Description

The RHF0M062 embeds the high-performance LoRa Chip SX1262 and Cypress 4100s MCU, which is suitable for end device of IOT.

Based on the powerful functions and performance of SX1262, the RHF0M062 could operate in both (G)FSK and LoRa mode. In LoRa mode, BW with 62.5kHz, 125kHz, 250kHz and 500kHz could be used. The module could provide UART, I2C, ADC and some others GPIOs for customer to extend their application. Two wire interface (SWIM) is suggested to be used for programming.

RHF0M062 is available in two optional models, RHF0M062-LF22 and RHF0M062-HF22. The RHF0M062-LF22 supports 21dBm@LF band (470MHz), while the RHF0M062-HF22 supports 22dBm@HF band (868MHz/915MHz).

### 1.1 Schematic diagram

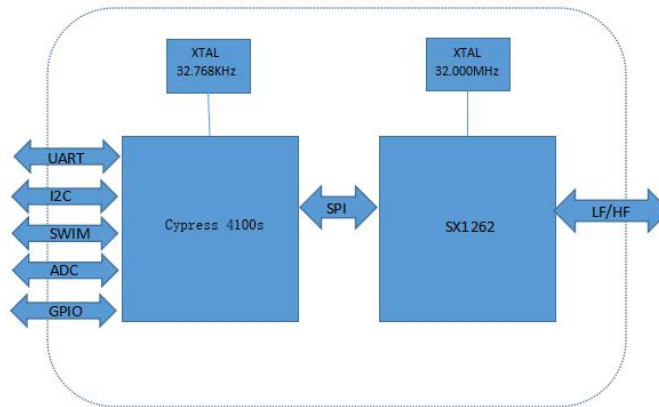

Figure 2 RHF0M062 schematic diagram

### 1.2 Pin definition

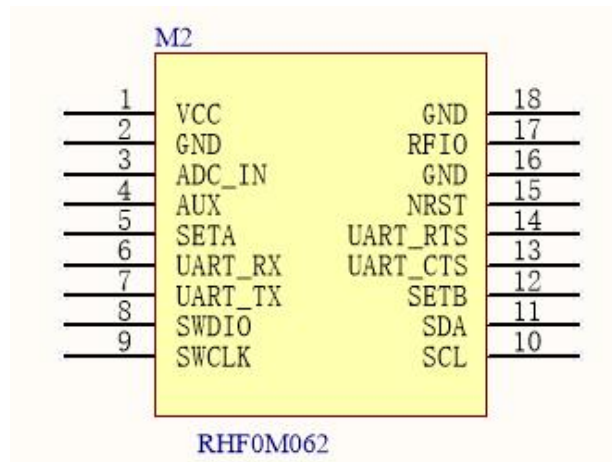

Figure 3 Pin definition of RHF0M062

**Table 1 Pin description**

Number	Name	Type	Description
1	VCC	-	Supply voltage for the module
2	GND	-	Ground
3	ADC_IN	I	ADC Input;P2.3
4	AUX	I/O	MCU GPIO;P6.2
5	SETA	I/O	MCU GPIO;P6.4
6	UART_RX	I/O	UART_RX from MCU;P3.0
7	UART_TX	I/O	UART_TX from MCU;P3.1
8	SWDIO	I/O	SWDIO of SWIM for program download
9	SWCLK	I/O	SWCLK of SWIM for program download
10	SCL	I/O	SCL of I2C from MCU;P0.0
11	SDA	I/O	SDA of I2C from MCU;P0.1
12	SETB	I/O	MCU GPIO;P0.2; Boot pin(Active low)
13	UART_CTS	I/O	UART CTS PIN;P0.6
14	UART_RTS	I/O	UART RTS PIN;P0.7
15	NRST	I	Reset trigger input for MCU
16	GND	-	Ground
17	RFIO	I/O	RF input/output
18	GND	-	Ground

## 2 Electrical Characteristics

### 2.1 Absolute Maximum Ratings

As stated that the values listed below may cause permanent device failure. Exposure to absolute maximum ratings for extended periods may affect device reliability.

**Table 2 Absolute Maximum Ratings**

Item	Description	min	max	unit
VCCmr	Supply voltage	-0.3	+3.9	V
Tmr	Temperature	-55	+115	°C
Pmr	RF input level	-	+10	dBm

### 2.2 Operating Range

**Table 3 Operating Range**

Item	Description	min	max	unit
VCCop	Supply voltage	+1.8	+3.6	V
Top	Temperature	-40	+85	°C
Pop	RF input level	-	+10	dBm

### 2.3 Module Specifications

Table 4 Module Specifications

ITEMs	Parameter	Specifications	Unit
<b>Structure</b>	Size	14(W) X 15(L) X 3(H)	mm
	Package	18 pins, SMT	
<b>Electrical Characteristics</b>	power supply	Typical 3.3V	V
	Sleep current	2.7uA (WDT off);4.3uA(WDT on)	uA
	TX current	100mA @21dBm in 470MHz typical	mA
		130mA @22dBm in 868MHz/915MHz typical	
	RX current	5.7mA @BW125kHz, 470MHz type	mA
		5.7mA @BW125kHz, 868MHz/915MHz type	
	Output power	21dBm max @470MHz	dBm
		22dBm max @868MHz/915MHz	
	Sensitivity	-138dBm @SF12, BW125kHz, 470MHz	dBm
		-137.5dBm @SF12, BW125kHz, 868MHz/915MHz	
Harmonics (LF Output)	<-36dBm below 1GHz	dBm	
	<-40dBm above 1GHz		
Harmonics (HF output)	<-40dBm above 1GHz		
<b>Interface</b>	RFIO	RF port	
	UART	1 group of UART, include 2pins	
	I2C	1 group of I2C, include 2 pins	
	ADC	1 ADC Input, include 1pins,12-bit 1Msps	
	NRST	Manual reset pin input	



## 3 Typical Performance

### 3.1 RHF0M062-LF22 measurement

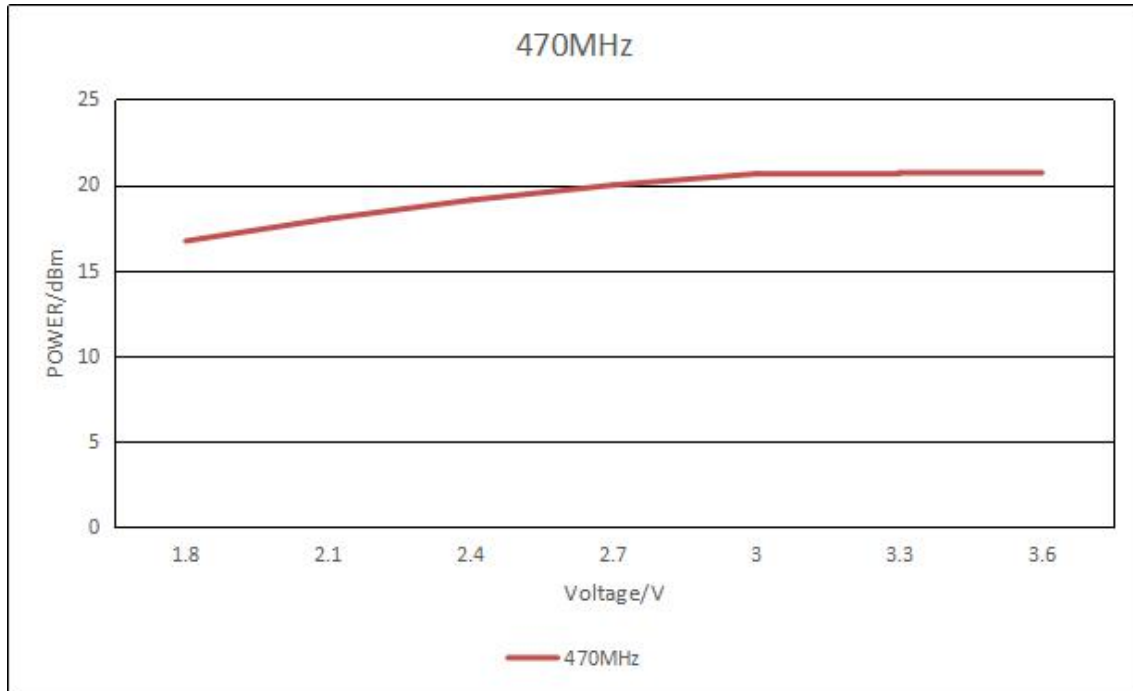

Figure 4 TXOP vs Supply voltage (470MHz)

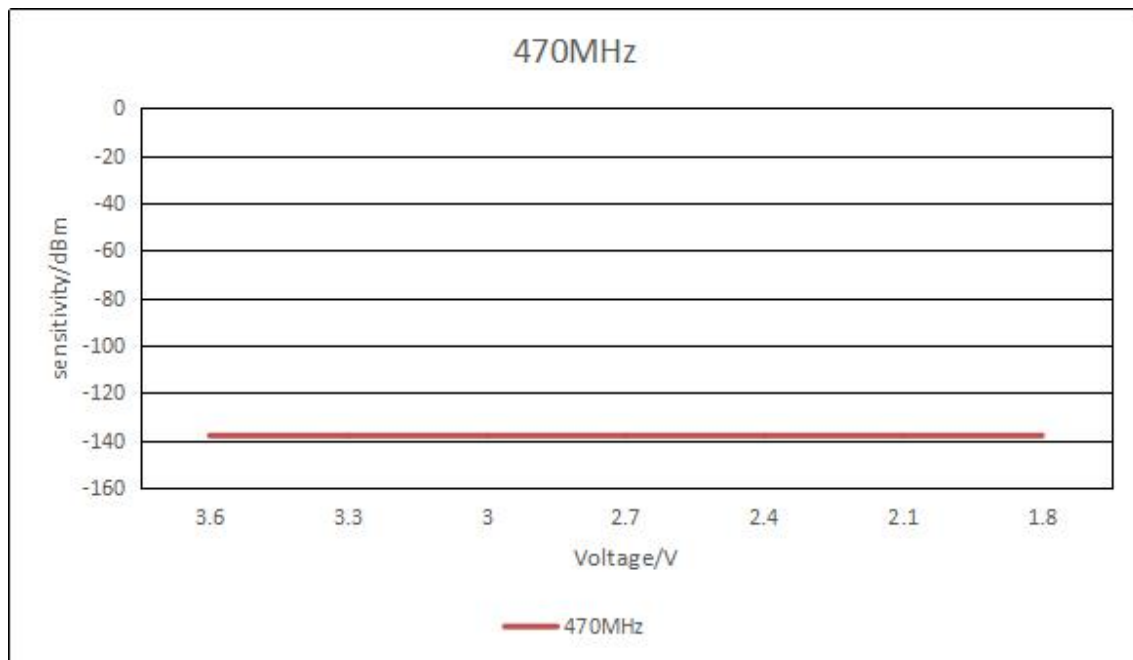

Figure 5 Sensitivity (SF12,125kHz) vs Supply voltage (470MHz)

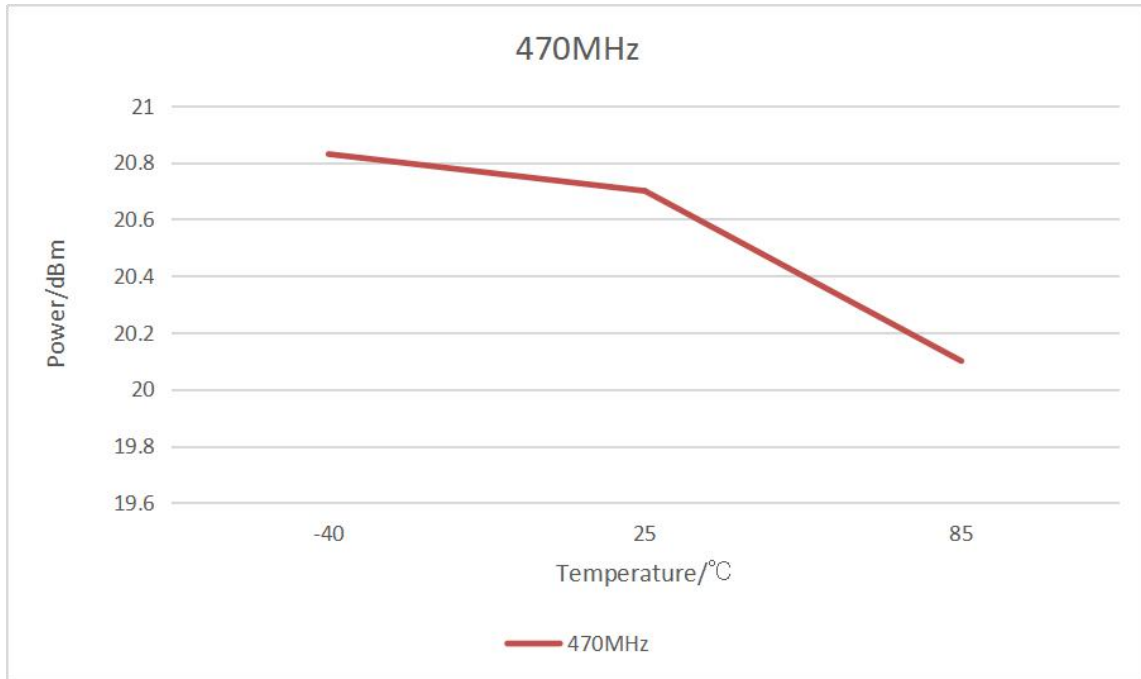

Figure 6 TXOP vs Temperature

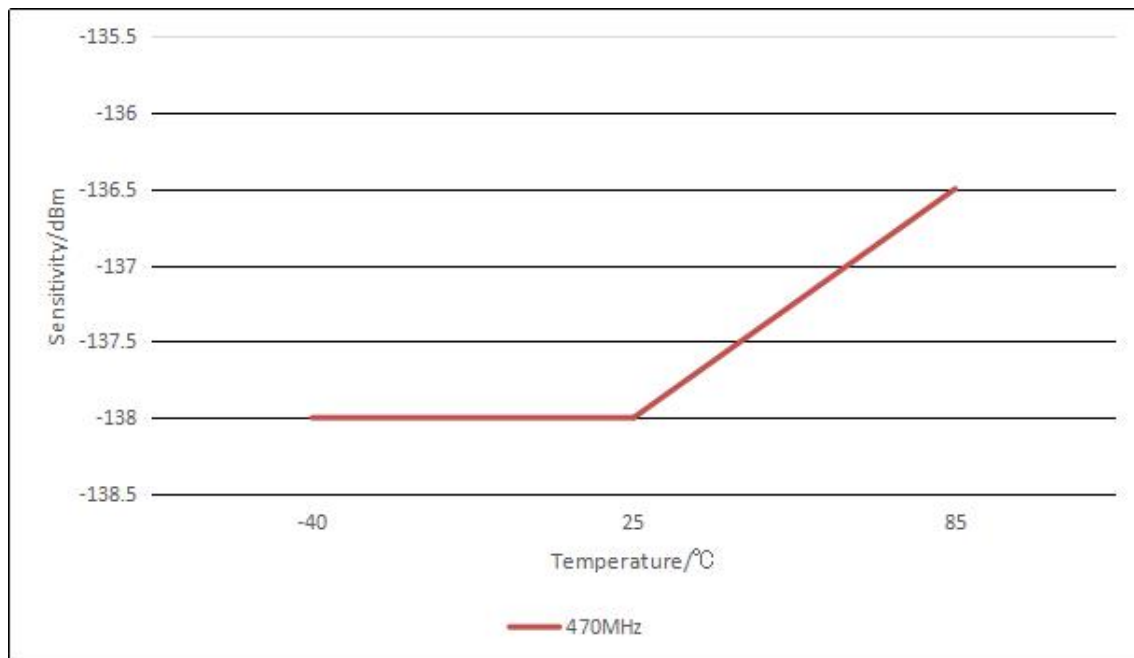

Figure 7 Sensitivity (SF12,125kHz) vs temperature



Figure 8 Harmonics measurement @Frf=470MHz, TXOP=21dBm (470MHz)

## 3.2 RHF0M062-HF22 measurement

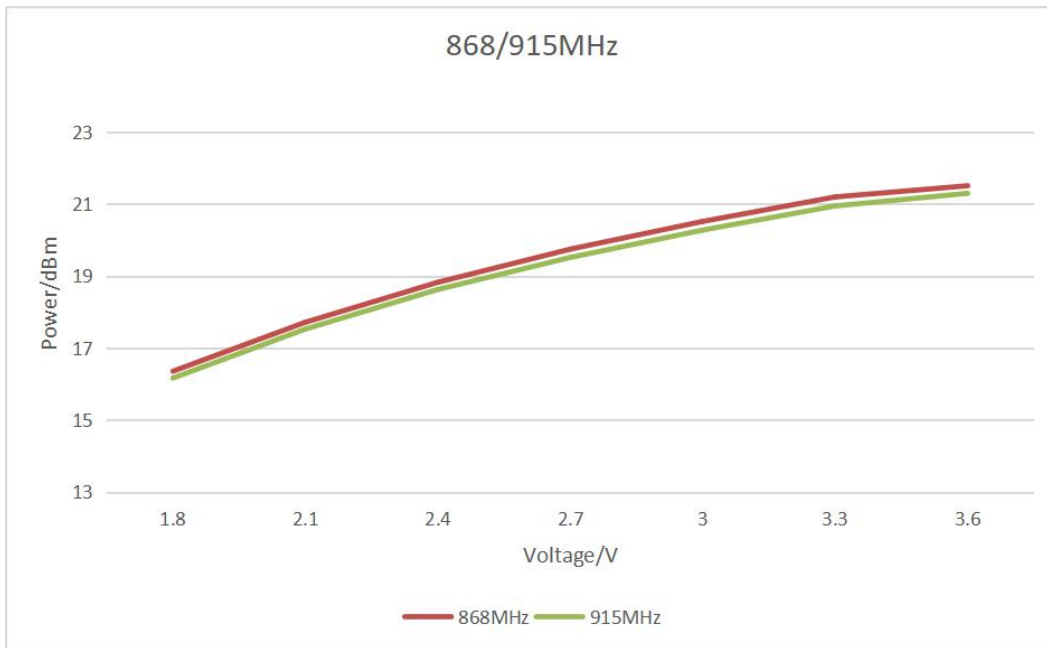

Figure 9 TXOP vs Supply voltage (868/915MHz)

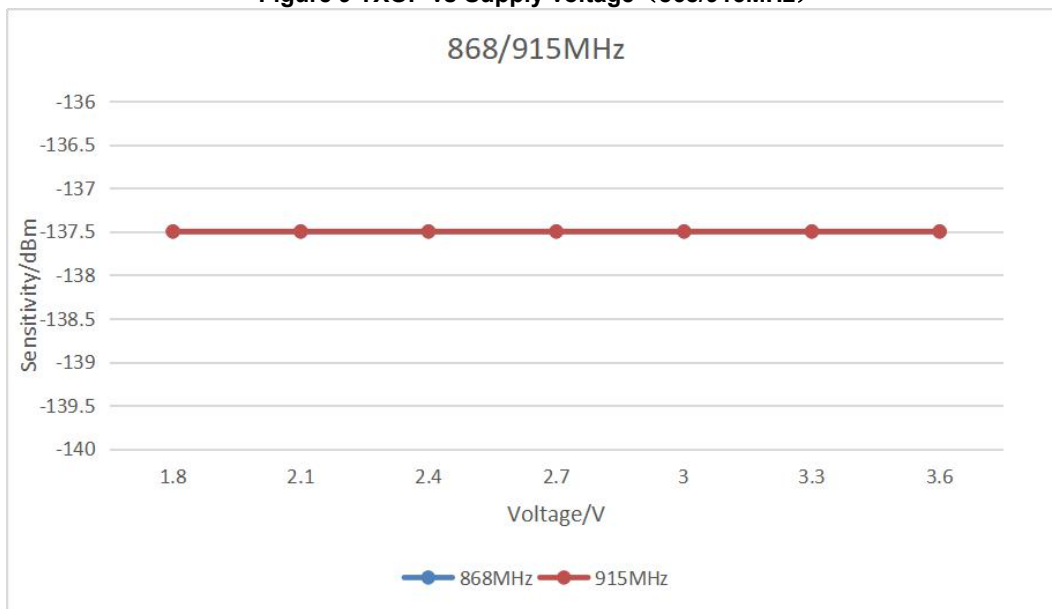

Figure 10 Sensitivity (SF12,125kHz) vs Supply voltage (868/915MHz)

Remarks: 868/915 receiving sensitivity test data overlap

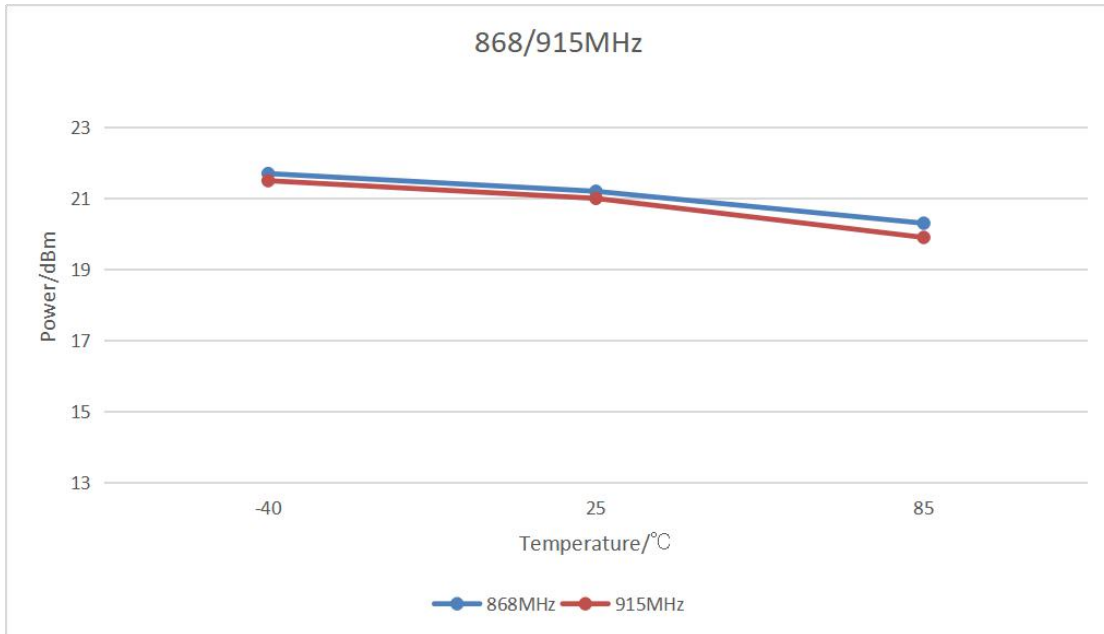

Figure 11 TXOP vs Temperature (868/915MHz)

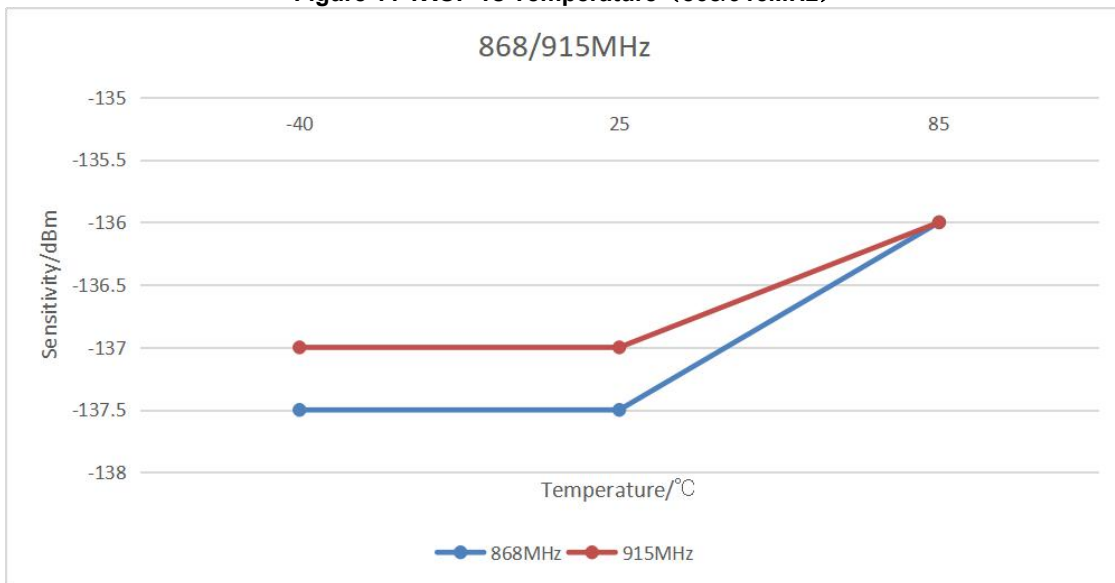

Figure 12 Sensitivity (SF12,125kHz) vs temperature

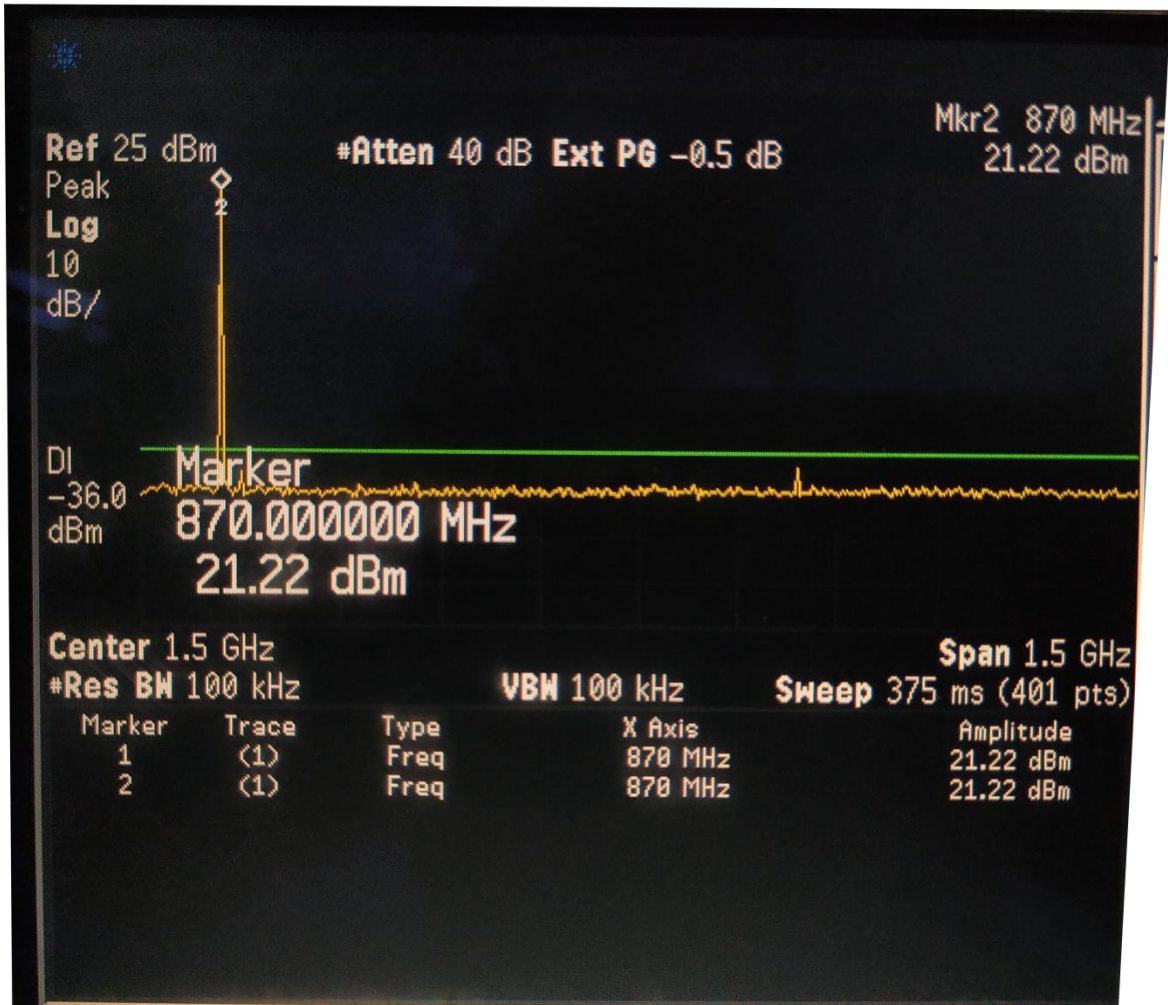

Figure 13 Harmonics measurement @Frf=868MHz, TXOP=22dBm (868MHz)

## 4 Application Information

### 4.1 Package Information

THE RHF0M062 is available in a 18-lead SMD package as shown below:

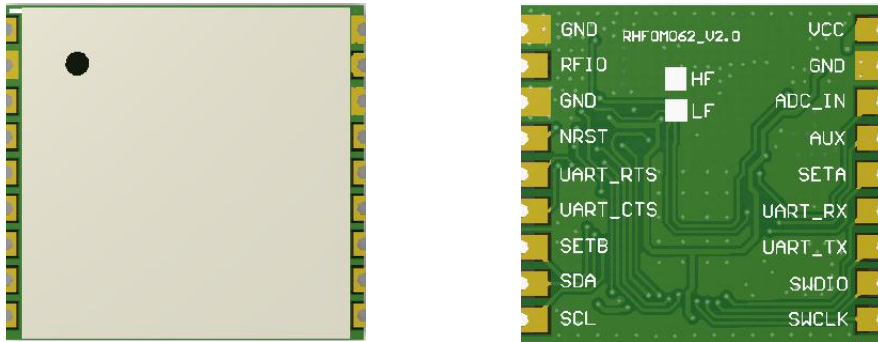

Figure 14 RHF0M062 package outline drawing

Below is the recommended land pattern for layout.

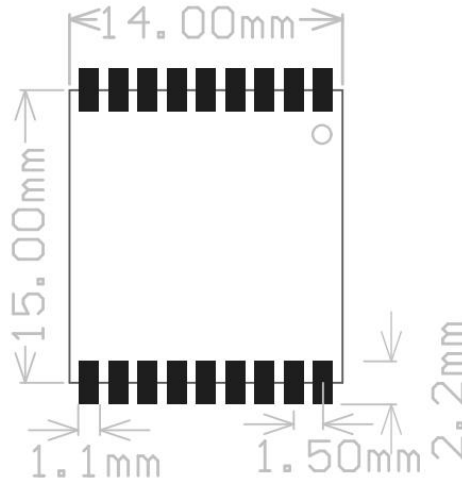

Figure 15 Recommended land pattern

### 4.2 Interface of Module

Except that several essential GPIOs and one group of SPI would be used for internal transceiver control, all others GPIOs and interface of the MCU would be connected to external pins of the module, which includes UART, I2C, ADC and so on.

### 4.3 Reference design with RHF0M062 Module

RHF0M062 is integrated with LoRaWAN protocol and AT command. LoRaWAN node design with RHF0M062 is very simple. Just connect the UART and NRST to their host MCU with AT command.

In addition, the module's Pin12 grounding will force the module into the Boot upgrade mode.

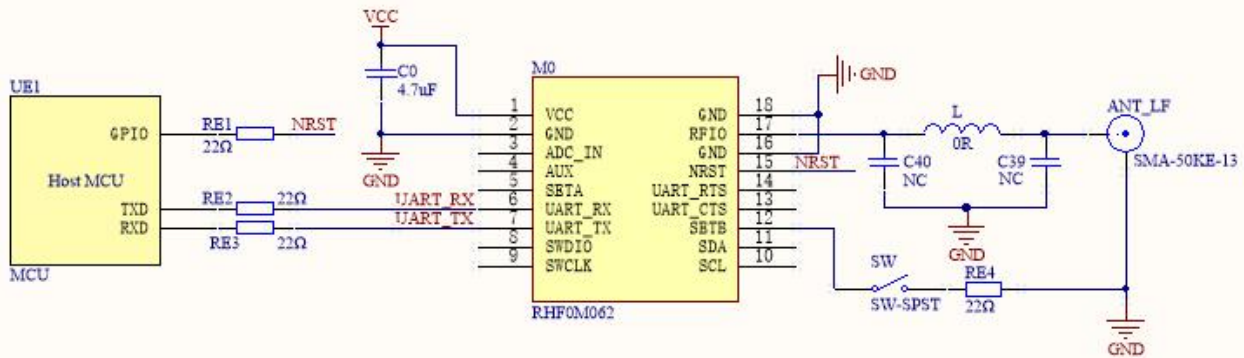

Figure 16 Reference design with RHF0M062

## 5 Application in LoRaWAN

### 5.1 LoRaWAN

LoRaWAN network is typically a star topology in which gateways relay messages between end-devices and a central network server. Gateways are connected to the network server via standard IP connections while end devices use single-hop LoRa™ or FSK communication to one or many gateways. All communication is generally bi-directional, although uplink communication from an end device to the network server is expected to be the predominant traffic.

Communication between end-devices and gateways is spread out on different frequency channels and data rates. The selection of the data rate is a trade-off between communication range and message duration, communications with different data rates do not interfere with each other. LoRa data rates range from 0.3 kbps to 50 kbps, with different Bandwidth and Spreading Factor. To maximize both battery life of the end-devices and overall network capacity, the LoRa network infrastructure can manage the data rate and RF output for each end-device individually by means of an adaptive data rate (ADR) scheme.

End-devices may transmit on any channel available at any time, using any available data rate, as long as the following rules are respected:

- 1) The end-device changes channel in a pseudo-random sequence for each transmission. This results in frequency diversity and makes the system more robust to interference.
- 2) The end-device respects the maximum transmit duty cycle relative to the sub-band used and local regulations.



RHF0M062 module integrates Semtech SX126x chip and Cypress ultra-low-power MCU. With a current of only 2.7uA in sleep mode, this module is ideal for a wide range of applications in LoRaWAN.

### 5.2 LoRaWAN sensor with RHF0M062

RHF0M062 is AT command based LoRaWAN modem, which is LoRaWAN protocol integrated. Customer just need to use a simple host MCU with application to control the modem via UART so that a LoRaWAN sensor could be designed easily. This will help customer to design and promote their sensor devices to market quickly.

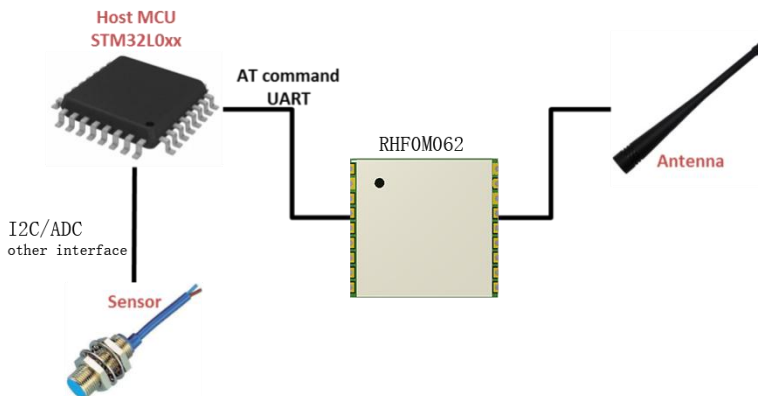

Figure 17 LoRaWAN sensor with RHF0M062

## 6 Ordering information

Technical Support: [support@risinghf.com](mailto:support@risinghf.com)

Business:

China: [Salescn@RisingHF.com](mailto:Salescn@RisingHF.com)

Others: [Salesww@RisingHF.com](mailto:Salesww@RisingHF.com)

Website: [www.risinghf.com](http://www.risinghf.com)

Table 5 Ordering information

Part Number	MCU	TX Power (dBm)	AT Modem
RHF0M062-LF22	ROM 128KB / RAM 16KB	21@LF (470MHz)	Yes
RHF0M062-HF22	ROM 128KB / RAM 16KB	22@HF (868/915MHz)	Yes

## Revision

---

V3.0 2019-04-02

+Add test data and final review of RHF0M062\_HF22;

V2.0 2018-12-18

+Correct the test data and delete the related content of RHF0M062\_HF22;

V1.0 2018-11-18

+ Draft Creation

## **Please Read Carefully:**

Information in this document is provided solely in connection with RisingHF products. RisingHF reserve the right to make changes, corrections, modifications or improvements, to this document, and the products and services described herein at any time, without notice.

All RisingHF products are sold pursuant to RisingHF's terms and conditions of sale.

Purchasers are solely responsible for the choice, selection and use of the RisingHF products and services described herein, and RisingHF assumes no liability whatsoever relating to the choice, selection or use of the RisingHF products and services described herein.

No license, express or implied, by estoppel or otherwise, to any intellectual property rights is granted under this document. If any part of this document refers to any third party products or services it shall not be deemed a license grant by RisingHF for the use of such third party products or services, or any intellectual property contained therein or considered as a warranty covering the use in any manner whatsoever of such third party products or services or any intellectual property contained therein.

UNLESS OTHERWISE SET FORTH IN RISINGHF'S TERMS AND CONDITIONS OF SALE RisingHF DISCLAIMS ANY EXPRESS OR IMPLIED WARRANTY WITH RESPECT TO THE USE AND/OR SALE OF RisingHF PRODUCTS INCLUDING WITHOUT LIMITATION IMPLIED WARRANTIES OF MERCHANTABILITY, FITNESS FOR A PARTICULAR PURPOSE (AND THEIR EQUIVALENTS UNDER THE LAWS OF ANY JURISDICTION), OR INFRINGEMENT OF ANY PATENT, COPYRIGHT OR OTHER INTELLECTUAL PROPERTY RIGHT.

RISINGHF PRODUCTS ARE NOT DESIGNED OR AUTHORIZED FOR USE IN: (A) SAFETY CRITICAL APPLICATIONS SUCH AS LIFE SUPPORTING, ACTIVE IMPLANTED DEVICES OR SYSTEMS WITH PRODUCT FUNCTIONAL SAFETY REQUIREMENTS; (B) AERONAUTIC APPLICATIONS; (C) AUTOMOTIVE APPLICATIONS OR ENVIRONMENTS, AND/OR (D) AEROSPACE APPLICATIONS OR ENVIRONMENTS. WHERE RISINGHF PRODUCTS ARE NOT DESIGNED FOR SUCH USE, THE PURCHASER SHALL USE PRODUCTS AT PURCHASER'S SOLE RISK, EVEN IF RISINGHF HAS BEEN INFORMED IN WRITING OF SUCH USAGE, UNLESS A PRODUCT IS EXPRESSLY DESIGNATED BY RISINGHF AS BEING INTENDED FOR "AUTOMOTIVE, AUTOMOTIVE SAFETY OR MEDICAL" INDUSTRY DOMAINS ACCORDING TO RISINGHF PRODUCT DESIGN SPECIFICATIONS. PRODUCTS FORMALLY ESCC, QML OR JAN QUALIFIED ARE DEEMED SUITABLE FOR USE IN AEROSPACE BY THE CORRESPONDING GOVERNMENTAL AGENCY.

Resale of RisingHF products with provisions different from the statements and/or technical features set forth in this document shall immediately void any warranty granted by RisingHF for the RisingHF product or service described herein and shall not create or extend in any manner whatsoever, any liability of RisingHF.

RisingHF and the RisingHF logo are trademarks or registered trademarks of RisingHF in various countries.

Information in this document supersedes and replaces all information previously supplied.

The RisingHF logo is a registered trademark of RisingHF. All other names are the property of their respective owners.

© 2015 RISINGHF - All rights reserved

<http://www.risinghf.com>