

## RHF-DS01500

## RHF76-052 LoRaWAN Module

---

V0.7

### Document information

Info	Content
<b>Keywords</b>	<i>RisingHF, LoRaWAN, Module</i>
<b>Abstract</b>	This document is a datasheet of RHF76-052 LoRaWAN module.

---

## RHF76-052 LoRaWAN Module

### Low Power Small Size High integrated LoRaWAN Module

#### General description

RHF76-052 LoRaWAN Module is a low cost, low power and small size module, embedded with Semtech's LoRa propriety chip SX1276 and ST's ultra-low power MCU STM32L051/052xx. The module designed by RisingHF (Shenzhen) is targeted to application in sensor network and others IOT devices powered by battery which need low power consumption to extend the battery lifetime.

This datasheet will give some details of description of the module, including HW design info, performance validation, and application information.

#### Applications

The RHF76-052 LoRaWAN Module is designed for end device which need long range and low power consumption, such as metering, sensor network, and others IOT application.

#### Key features

- ◆ Low power consumption: 1.45uA sleep current in WOR mode
- ◆ Low cost: SX1276 with cost-effective MCU; 2 layers layout
- ◆ Small size: 23mm X 28mm
- ◆ 33 pins SMT package
- ◆ Dual band:

410~525MHz

860MHz~1020MHz

- ◆ High performance:
  - RHF76-052DM (Dual Band):  
TXOP=19dBm@410~525MHz  
TXOP=14dBm@860MHz~1020MHz
  - RHF78-52AL (Single Band):  
TXOP=19dBm@410~525MHz
  - RHF76-52CL (Single Band):  
TXOP=19dBm@860MHz~1020MHz

160dB link budget, suitable for long range

- ◆ User-friendly interface
  - SPI;
  - USART;
  - I2C;
  - USB;
  - ADC;
  - 10 more GPIOs
- ◆ LoRaWAN embedded with AT command:
  - EU868;
  - US915 and US915 Hybrid;
  - CN779;
  - EU433;
  - AU915;
  - CN470 and CN470 Prequel;
  - AS923;
  - KR920;
  - IN865;



Figure 1 RHF76-052 Module Outline

## Content

1	General description.....	1
1.1	Simplified Block Diagram.....	1
1.2	Pin description.....	2
2	Electrical Characteristics.....	3
2.1	Absolute Maximum Ratings.....	3
2.2	Operating Range.....	3
2.3	Module Specifications.....	3
3	Typical Performance Characteristics Measurement.....	4
4	Application Information.....	10
4.1	Package Information.....	10
4.2	Interface of Module.....	11
4.3	Reference design with RHF76-052 Module.....	11
5	Application in LoRaWAN.....	12
5.1	LoRaWAN/LoRaMAC.....	12
5.2	RHF76-052 with LoRaWAN.....	12
5.3	LoRaWAN sensor with RHF76-052DM.....	14
6	Ordering information.....	15
	Revision History.....	16

## Figures

Figure 1 RHF76-052 Module Outline.....	2
Figure 2 Block Diagram of RHF76-052.....	1
Figure 3 Pin diagram.....	2
Figure 4 TXOP vs Supply voltage.....	5
Figure 5 Sensitivity (SF10,125kHz) vs Supply voltage.....	6
Figure 6 Frequency Tolerance vs Temperature.....	6
Figure 7 TXOP vs Temperature.....	7
Figure 8 Sensitivity (SF12,125kHz) vs temperature.....	7
Figure 9 Harmonics measurement @Frf=434MHz, TXOP=19dBm.....	8
Figure 10 Harmonics measurement @Frf=470MHz, TXOP=19dBm.....	8
Figure 11 Harmonics measurement @Frf=868MHz, TXOP=14dBm.....	9
Figure 12 Harmonics measurement @Frf=915MHz, TXOP=14dBm.....	9
Figure 13 package outline drawing.....	10
Figure 14 Recommended land pattern.....	10
Figure 15 Label information of RHF76-052DM.....	11
Figure 16 Reference design with RHF76-052.....	11
Figure 17 Energy profile of RHF76-052 application in LoRaWAN.....	13
Figure 18 Energy profile of RHF76-052 application in LoRaWAN.....	14
Figure 19 LoRaWAN sensor with RHF76-052DM.....	14

## Tables

Table 1 Pin description.....	2
Table 2 Absolute Maximum Ratings.....	3
Table 3 Operating Range.....	3
Table 4 Module Specifications.....	3
Table 5 RHF76-052DM Tx output power @ 470MHz~510MHz.....	4
Table 6 RHF76-052DM Rx sensitivity @ 470MHz~490MHz.....	4
Table 7 RHF76-052DM Tx output power @ 902MHz~928MHz.....	5
Table 8 RHF76-052DM Rx sensitivity @ 902MHz~928MHz.....	5
Table 9 Ordering information.....	15

This product datasheet contains a detailed description of the RHF76-052 performance and functionality. Please consult with RisingHF for the latest updates, Firmware or errata.

## 1 General description

The RHF76-052 incorporates SX1276 and STM32L052xx, and is well suited for node in the networking of IOT.

The module has two RF port, RFIO\_LF and RFIO\_HF. RFIO\_LF covers low frequency band, i.e. 410~525MHz. RFIO\_HF covers high frequency band, i.e. 860~1020MHz.

Based on the powerful functions and performance of SX1276, the RHF76-052 could operates in both (G)FSK and LoRa. In LoRa mode, BW with 62.5kHz, 125kHz, 250kHz and 500kHz could be used.

And with the STM32L051xx/052xx MCU, the module could provide SPI, UART, I2C, ADC and some others GPIOs for customer to extend their application. Two wire interface (SWIM) is suggested to be used for programming.

### 1.1 Simplified Block Diagram

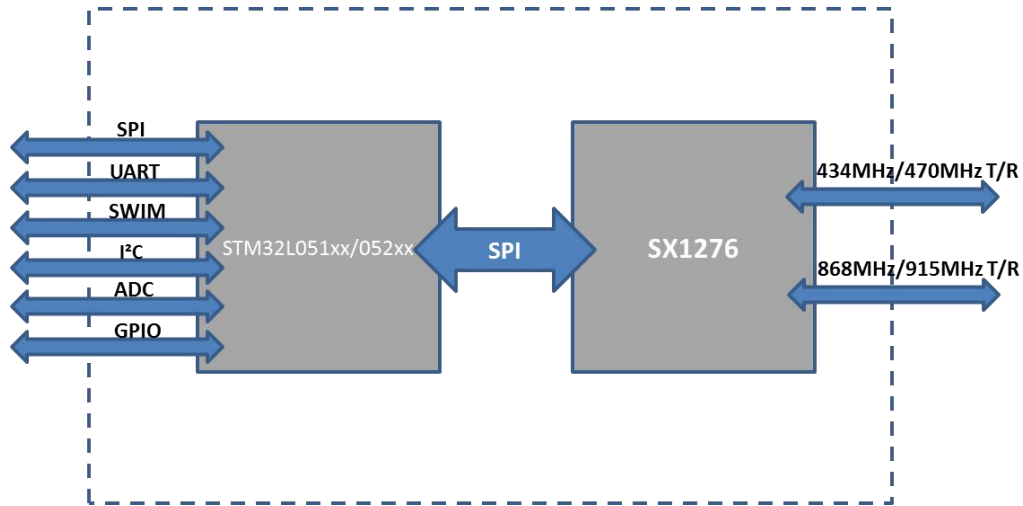

Figure 2 Block Diagram of RHF76-052

## 1.2 Pin description

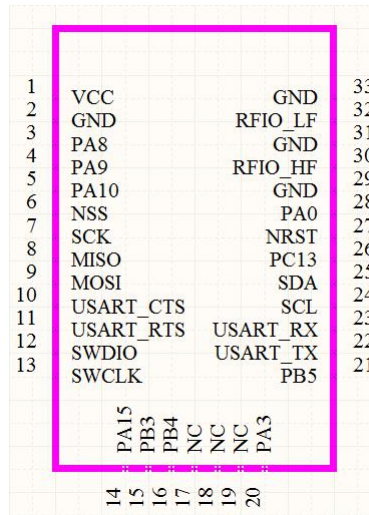

Figure 3 Pin diagram

Table 1 Pin description

Number	Name	Type	Description
1	VCC	-	Supply voltage for the module
2	GND	-	Ground
3	PA8	I/O	GPIO from MCU, PA8
4	PA9	I/O	GPIO from MCU, PA9
5	PA10	I/O	GPIO from MCU, PA10
6	NSS	I/O	NSS of SPI1 from MCU; or GPIO from MCU, PB12
7	SCK	I/O	SCK of SPI1 from MCU; or GPIO from MCU, PB13
8	MISO	I/O	MISO of SPI1 from MCU; or GPIO from MCU, PB14
9	MOSI	I/O	MOSI of SPI1 from MCU; or GPIO from MCU, PB15
10	USART1_CTS	I/O	USART1_CTS from MCU; or GPIO from MCU, PA11
11	USART1_RTS	I/O	USART1_RTS from MCU; or GPIO from MCU, PA12
12	SWDIO	I/O	SWDIO of SWIM for program download
13	SWCLK	I/O	SWCLK of SWIM for program download
14	PA15	I/O	GPIO from MCU, PA15
15	PB3	I/O	GPIO from MCU, PB3
16	PB4	I/O	GPIO from MCU, PB4
17	NC	-	Connected to Ground
18	NC	-	Connected to Ground
19	NC	-	Connected to Ground
20	PA3/ADC3	I/O	GPIO from MCU, PA3; or ADC3 input
21	PB5	I/O	GPIO from MCU, PB5
22	USART1_TX	I/O	USART1_TX from MCU; or GPIO from MCU, PB6
23	USART1_RX	I/O	USART1_RX from MCU; or GPIO from MCU, PB7

24	I2C_SCL	I/O	SCL of I2C from MCU; or GPIO from MCU, PB8
25	I2C_SDA	I/O	SDA of I2C from MCU; or GPIO from MCU, PB9
26	PC13/Wkup2	I/O	Wake up pin for MCU; or GPIO from MCU, PC13
27	NRST	I	Reset trigger input for MCU
28	PA0/AD0	I/O	GPIO from MCU, PA0; or ADC0 input
29	GND	-	Ground
30	RFIO_HF	-	RF input/output in high band, i.e. 860~1020MHz
31	GND	-	Ground
32	RFIO_LF	-	RF input/output in low band, i.e. 410~525MHz
33	GND	-	Ground

## 2 Electrical Characteristics

### 2.1 Absolute Maximum Ratings

As stated that the values listed below may cause permanent device failure. Exposure to absolute maximum ratings for extended periods may affect device reliability.

**Table 2 Absolute Maximum Ratings**

Item	Description	min	max	unit
VCCmr	Supply voltage	-0.3	+3.9	V
Tmr	Temperature	-55	+115	°C
Pmr	RF input level	-	+10	dBm

### 2.2 Operating Range

**Table 3 Operating Range**

Item	Description	min	max	unit
VCCop	Supply voltage	+1.8	+3.6	V
Top	Temperature	-40	+85	°C
Pop	RF input level	-	+10	dBm

### 2.3 Module Specifications

The tables below give the electrical specifications of the transceiver under the following conditions: Supply voltage VDD=3.3 V, temperature = 25 ° C. The DUT is **RHF76-052DM** unless otherwise specified.

**Table 4 Module Specifications**

ITEMS	Parameter	Specifications	Unit
<b>Structure</b>	Size	23(W) X 28(L) X 2.6(H)	mm
	Package	33 pins, SMT	
<b>Electrical</b>	power supply	3.3V type	V

<b>Characteristics</b>	Sleep current	1.45uA	uA
	Operation current (Transmitter+MCU)	120mA @19dBm in 410~525MHz type	mA
		45mA @14dBm in 860~1020MHz type	mA
	Operation current (Receiver+MCU)	16mA @BW125kHz, 410~525MHz type	mA
		15.5mA @BW125kHz, 860~1020MHz type	mA
	Output power	19dBm max @410~525MHz	dBm
		14dBm max @860~1020MHz	dBm
	Sensitivity	-139dBm @SF12, BW125kHz, 410~525MHz	dBm
		-137dBm @SF12, BW125kHz, 860~1020MHz	dBm
Harmonics (LF Output)	<-42dBm below 1GHz	dBm	
	<-35dBm above 1GHz	dBm	
Harmonics (HF output)	<-40dBm above 1GHz	dBm	
<b>Interface</b>	RFIO_LF	RF port for Low Band (410~525MHz)	
	RFIO_HF	RF port for High Band (860~1020MHz)	
	SPI	1 group of SPI, include 4 pins	
	USART	1 group of USART, include 2pins	
	USB	1 group of USB, include 2 pins	
	I2C	1 group of I2C, include 2 pins	
	ADC	2 ADC Input, include 2 pins	
	GPIOs	8 GPIOs more except the interface above	
	NRST	Manual reset pin input	

## 3 Typical Performance Characteristics Measurement

The tables below give the electrical specifications of the transceiver under the following conditions: Supply voltage VDD=3.3 V, temperature = 25 ° C. The DUT is RHF76-052DM unless otherwise specified.

**Table 5 RHF76-052DM Tx output power @ 470MHz~510MHz**

Freq/MHZ	465	470	475	480	485	490	495	500	505	510
Txop/dBm	18.89	18.63	18.7	18.61	18.53	18.6	18.85	18.68	18.75	18.8
H2/dBm	-50	-48	-46	-45	-44	-44	-45	-45	-46	-46
H3/dBm	-49	-50	-50	-50	-51	-51	-52	-52	-52	-53
H4/dBm	<-60	<-60	<-60	<-60	<-60	<-60	<-60	<-60	<-60	<-60
H5/dBm	<-60	<-60	<-60	<-60	<-60	<-60	<-60	<-60	<-60	<-60

**Table 6 RHF76-052DM Rx sensitivity @ 470MHz~490MHz**

Freq/MHZ	470	475	480	485	490
SF12	-139	-138	-138.5	-138.5	-138.5
SF11	-135.5	-136	-136	-136.5	-135
SF10	-132	-132	-133	-132	-132



SF9	-129.5	-129.5	-129	-129	-129
SF8	-127	-126.5	-126.5	-126.5	-126.5
SF7	-123	-123	-123	-123	-123

**Table 7 RHF76-052DM Tx output power @ 902MHz~928MHz**

Ferq /MHz	902	904	906	908	910	912	914	916	918	920	922	924	926	928
Txop /dBm	13.96	13.96	14.03	13.95	13.96	13.95	14.04	13.98	13.93	13.95	13.93	13.94	13.93	13.92
H2 /dBm	-48	-48	-47	-47	-47	-47	-47	-47	-47	-48	-48	-48	-48	-48
H3 /dBm	<60	<-60	<-60	<-60	<-60	<-60	<-60	<-60	<-60	<-60	<-60	<-60	<-60	-60

**Table 8 RHF76-052DM Rx sensitivity @ 902MHz~928MHz**

Freq /MHz	902	904	906	908	910	912	914	916	918	920	922	924	926	928
SF12	-138.5	-138.5	-138.5	-138	-138	-138.5	-138	-138	-138	-138	-138	-139	-138	-138
SF11	-135.5	-135.5	-135.5	-135	-135	-135	-135.5	-135	-135	-135	-135	-135	-135	-135
SF10	-132.5	-132.5	-132.5	-132	-132	-132	-132	-132	-132	-132	-132	-132	-132	-131.5
SF9	-129	-129	-129	-129	-129	-129	-129	-129	-129	-129	-129	-129	-129	-128.5
SF8	-127	-127	-127	-127	-127	-126.5	-126.5	-126.5	-126.5	-126.5	-126.5	-126.5	-126.5	-126
SF7	-124	-124	-123.5	-124	-123.5	-123.5	-124	-124	-123.5	-123.5	-123.5	-123	-123	-123

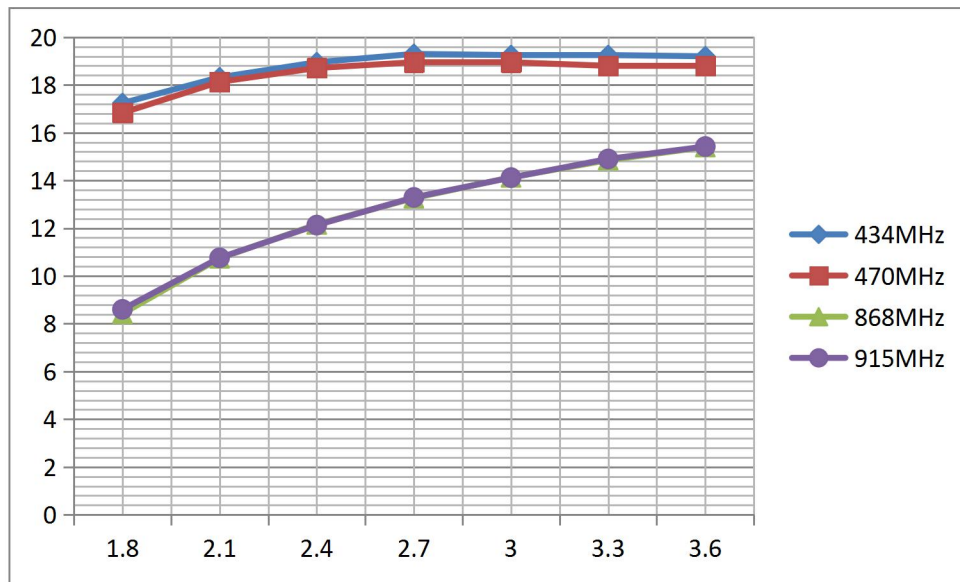

**Figure 4 TXOP vs Supply voltage**

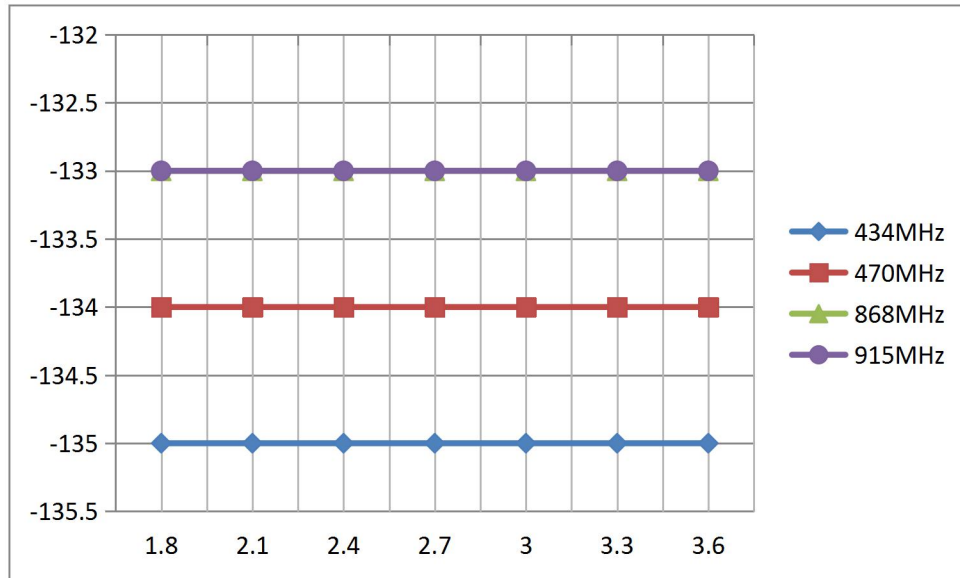

Figure 5 Sensitivity (SF10,125kHz) vs Supply voltage

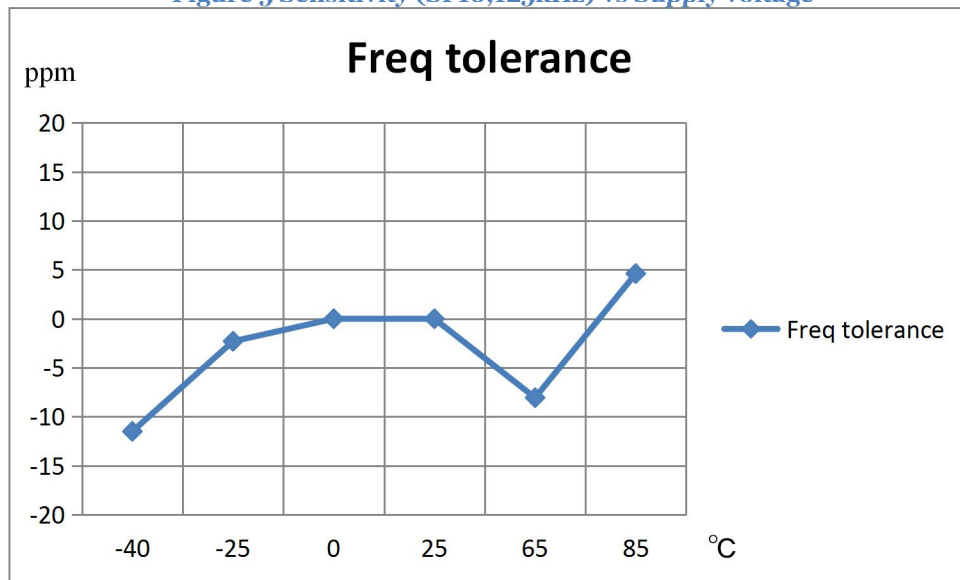

Figure 6 Frequency Tolerance vs Temperature

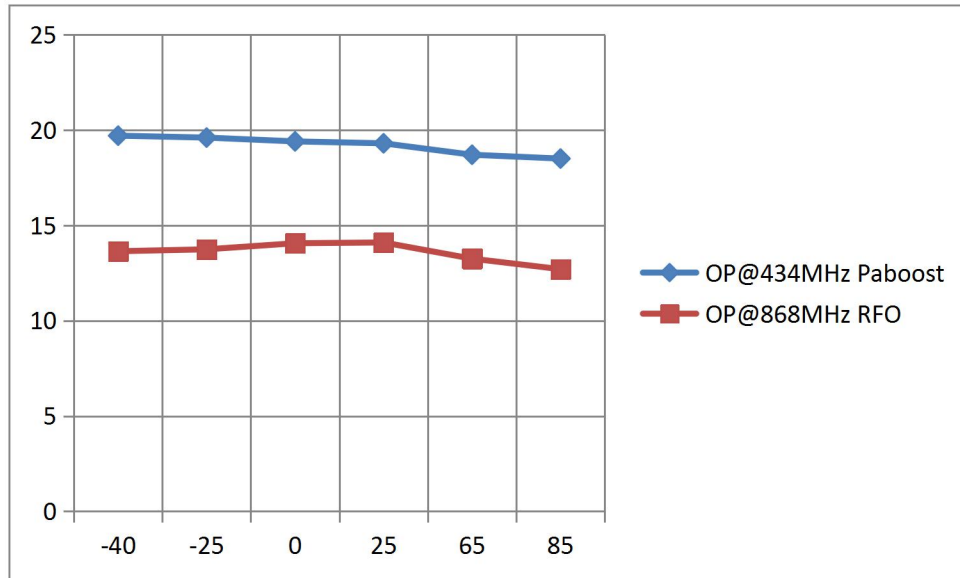

Figure 7 TXOP vs Temperature

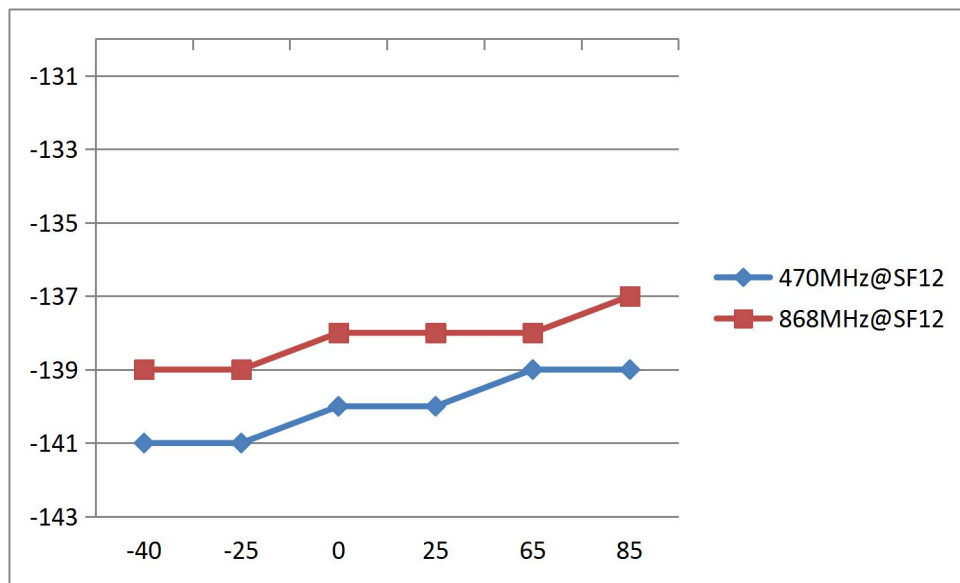

Figure 8 Sensitivity (SF12,125kHz) vs temperature

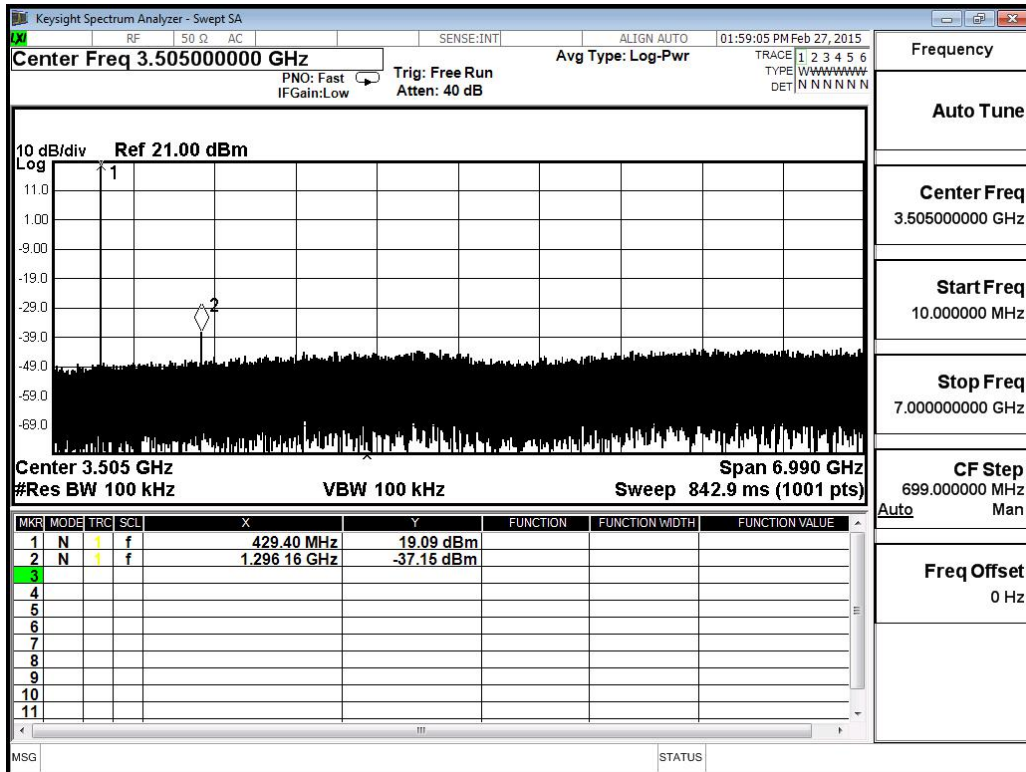

Figure 9 Harmonics measurement @Frf=434MHz, TXOP=19dBm

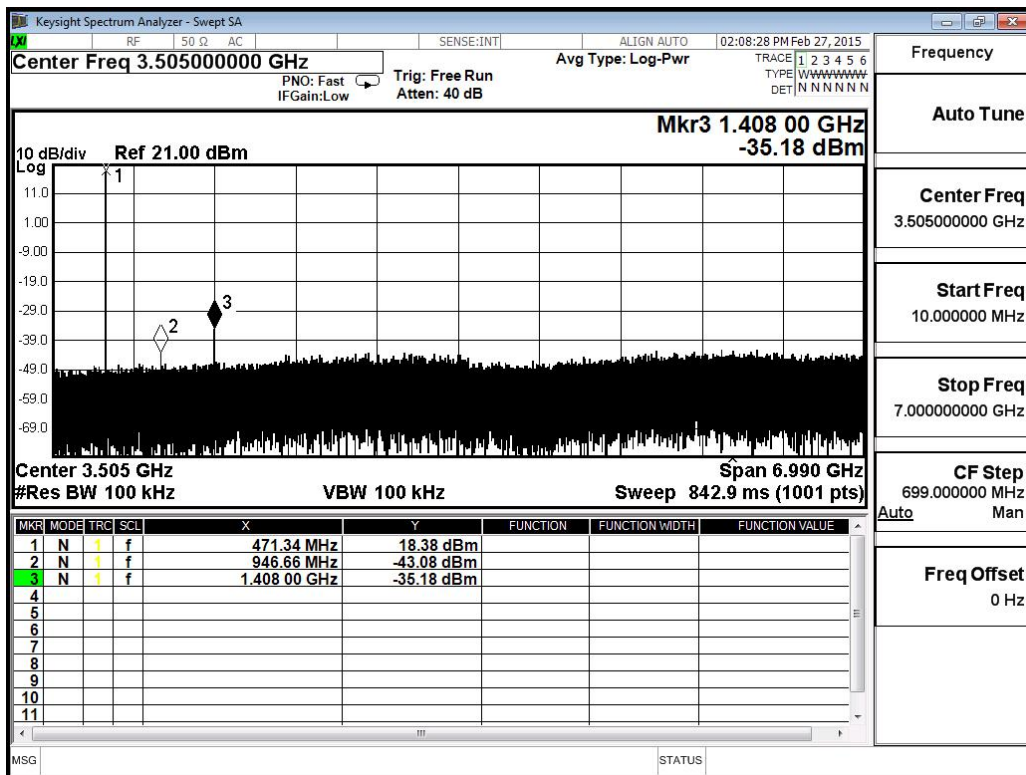

Figure 10 Harmonics measurement @Frf=470MHz, TXOP=19dBm

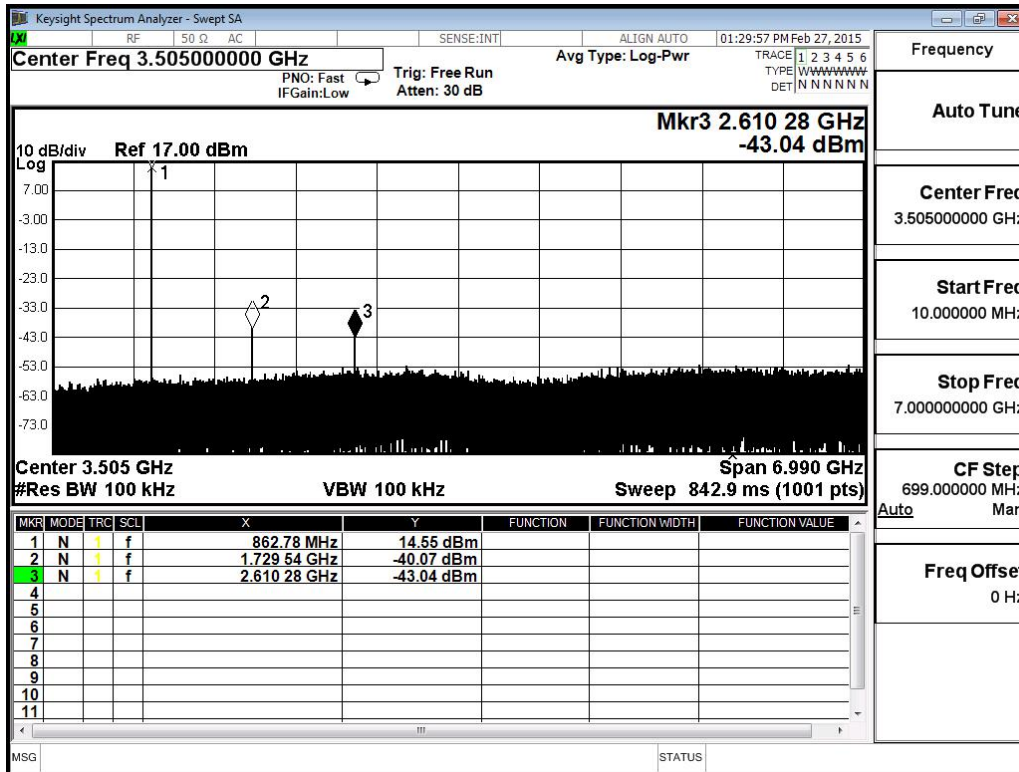

Figure 11 Harmonics measurement @Frf=868MHz, TXOP=14dBm

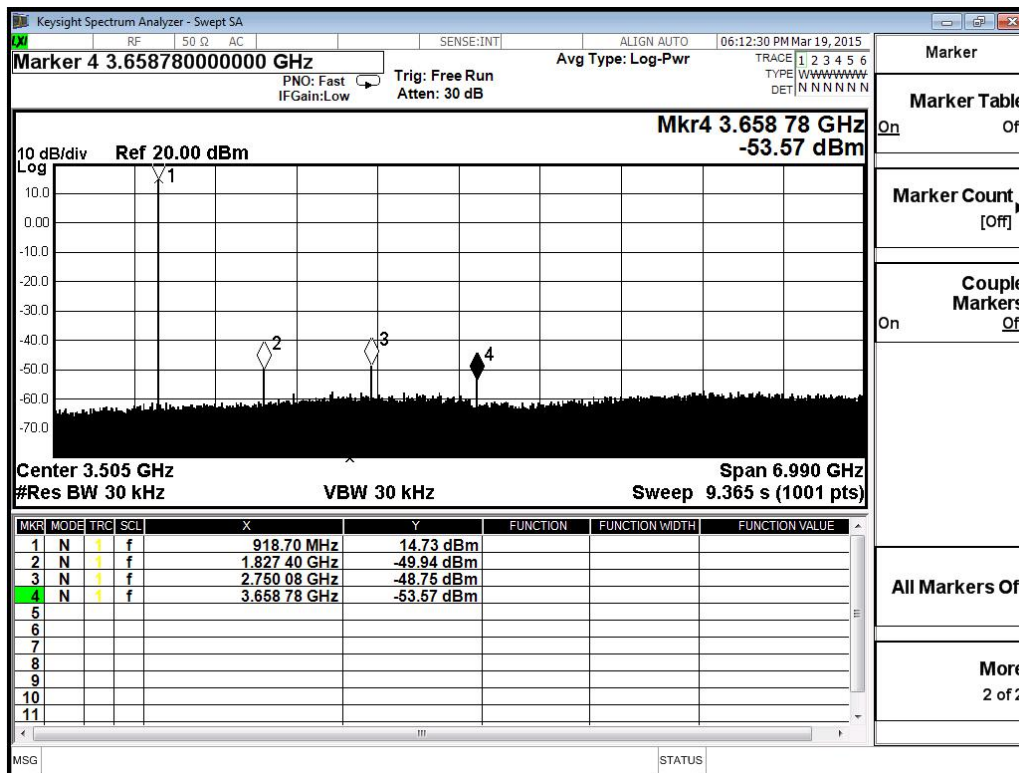

Figure 12 Harmonics measurement @Frf=915MHz, TXOP=14dBm

## 4 Application Information

### 4.1 Package Information

The RHF76-052 is available in a 33-lead SMD package as shown in Figure 13 below:

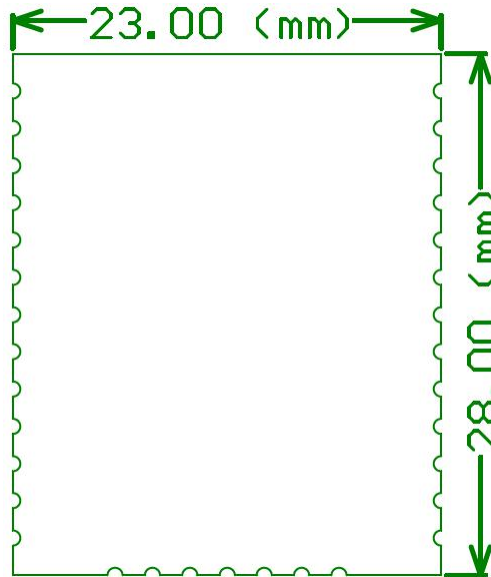

Figure 13 package outline drawing

Figure 14 show the recommended land pattern for layout.

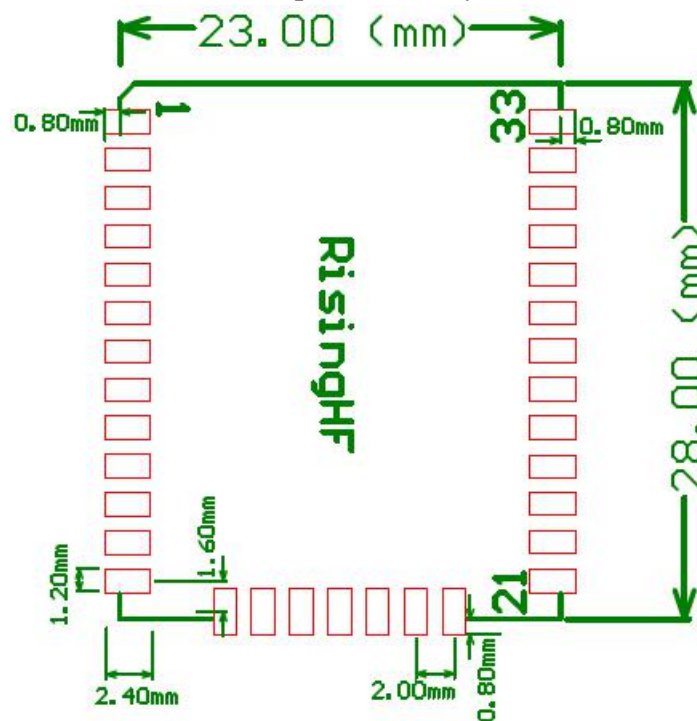

Figure 14 Recommended land pattern



Figure 15 Label information of RHF76-052DM

## 4.2 Interface of Module

Except that several essential GPIOs and one group of SPI would be used for internal transceiver control, all others GPIOs and interface of the MCU would be connected to external pins of the module, which includes SPI, USART, I2C, USB and 10 GPIOs. And there are 2 ADC included in the 10 GPIOs. This is very useful and important for customer to extend their design with these abundant GPIOs and interfaces. For more details of interface, please refer to Table 1 Pin description and datasheet of STM32L051xx/STM32L052xx.

## 4.3 Reference design with RHF76-052 Module

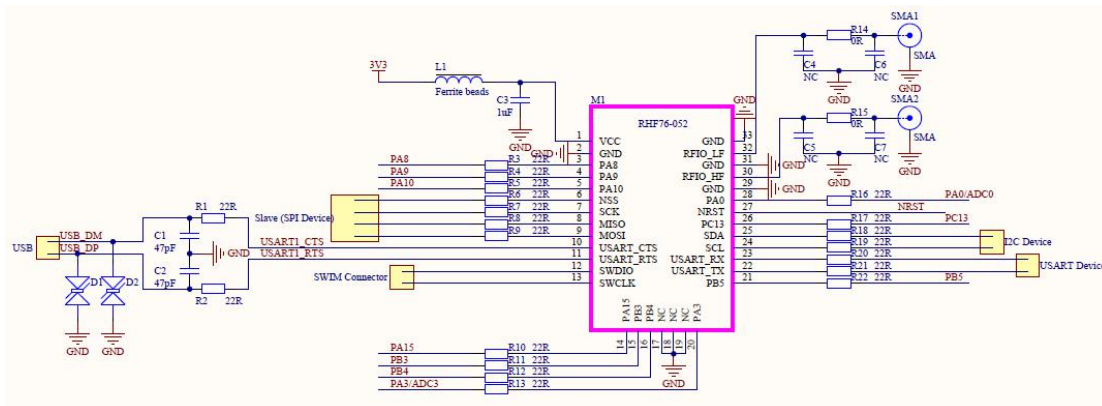

Figure 16 Reference design with RHF76-052

## 5 Application in LoRaWAN

### 5.1 LoRaWAN/LoRaMAC

LoRaWAN networks typically are laid out in a star-of-stars topology in which gateways relay messages between end-devices and a central network server at the backend. Gateways are connected to the network server via standard IP connections while end devices use single-hop LoRa™ or FSK communication to one or many gateways. All communication is generally bi-directional, although uplink communication from an end device to the network server is expected to be the predominant traffic. Communication between end-devices and gateways is spread out on different frequency channels and data rates. The selection of the data rate is a trade-off between communication range and message duration, communications with different data rates do not interfere with each other. LoRa data rates range from 0.3 kbps to 50 kbps, with different Band Width and Spreading Factor. To maximize both battery life of the end-devices and overall network capacity, the LoRa network infrastructure can manage the data rate and RF output for each end-device individually by means of an adaptive data rate (ADR) scheme.

End-devices may transmit on any channel available at any time, using any available data rate, as long as the following rules are respected:

- 1) The end-device changes channel in a pseudo-random fashion for every transmission. The resulting frequency diversity makes the system more robust to interferences.
- 2) The end-device respects the maximum transmit duty cycle relative to the sub-band used and local regulations.

The RHF76-052 Module incorporates Semtech's LoRa Chip SX1276 and ST's ultra-low power MCU. With only 1.45uA sleep current in WOR mode, the module is really very suitable for LoRaWAN application.

### 5.2 RHF76-052 with LoRaWAN

The Figure 16 and Figure 17 below show the power consumption of the RHF76-052 module. The code is optimized so that the MCU and all peripherals are in sleep mode most of the time.

In Figure 16, two RX windows will follow the TX window which is in accordance with LoRaWAN protocol. In the RX window<sub>1</sub>, the SF of the receiver would set to SF12 for example (should be same as the SF as previous uplink). When there is no packet received in the RX window<sub>1</sub>, the RX window<sub>2</sub> would occur. In the RX window<sub>2</sub>, the SF of the receiver would set to SF9 (depend on the spec).



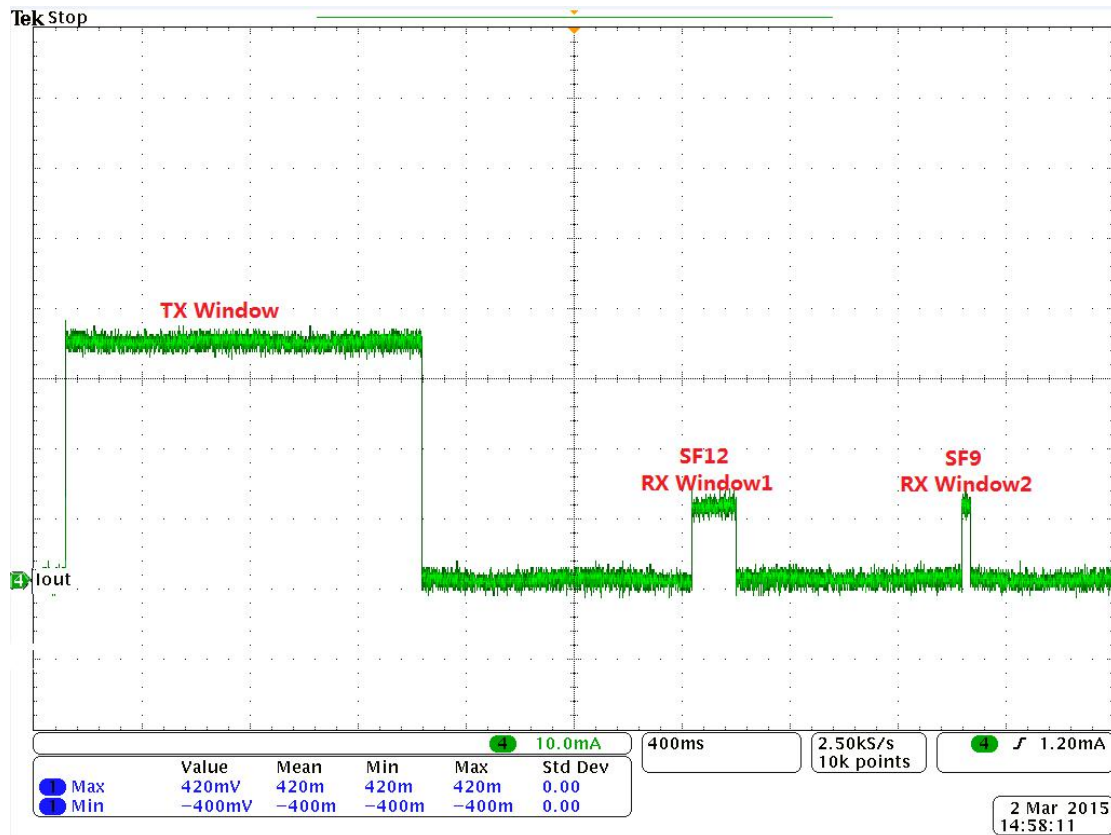

Figure 17 Energy profile of RHF76-052 application in LoRaWAN  
(No packet received from Server)

In Figure 17, the node receives the packet from server in the RX window1.

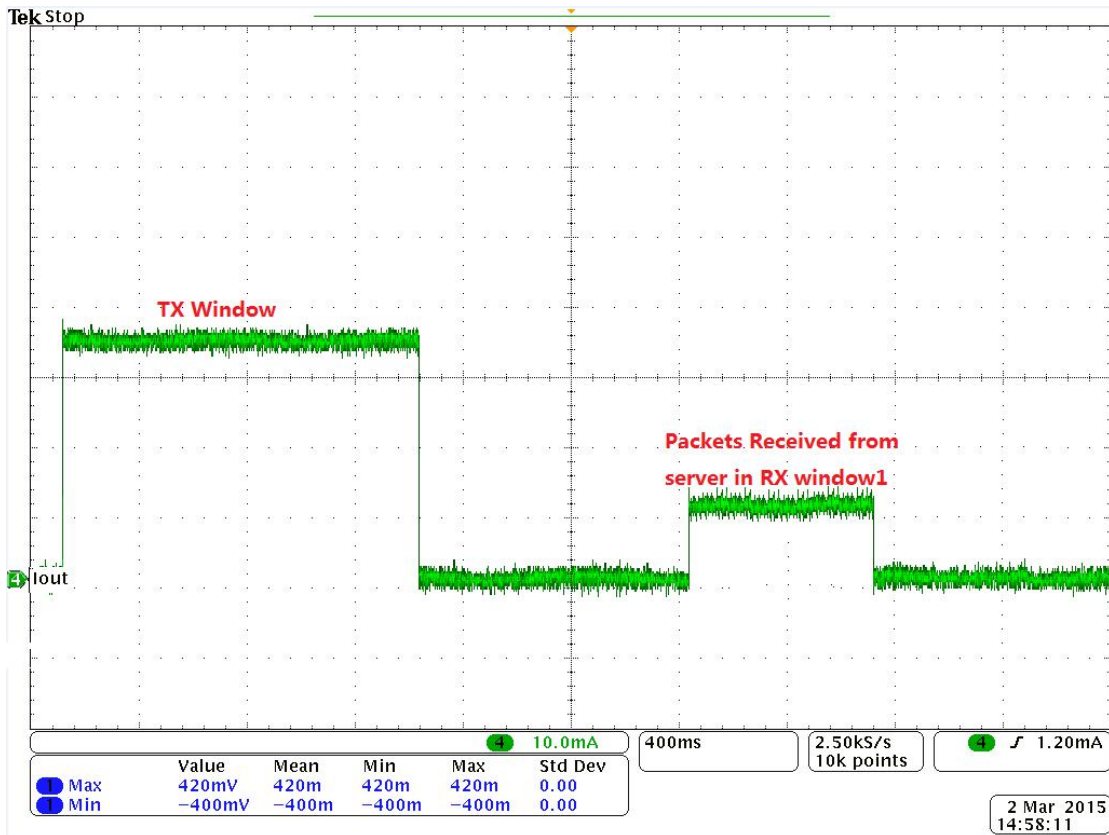

Figure 18 Energy profile of RHF76-052 application in LoRaWAN (A packet received from Server in RX window1)

## 5.3 LoRaWAN sensor with RHF76-052DM

RHF76-052DM is AT command LoRaWAN modem, which is LoRaWAN protocol embedded. Customer just need use a simple host mcu with application to control the modem via UART that a LoRaWAN sensor could be designed easily. This will help customer to promote their sensor devices to market quickly.

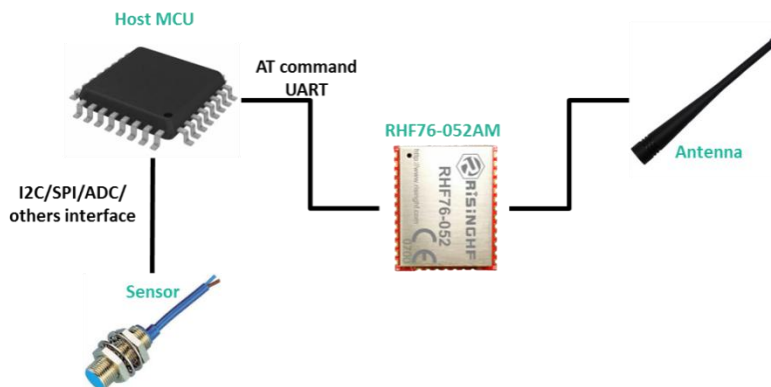

Figure 19 LoRaWAN sensor with RHF76-052DM

## 6 Ordering information

Technical Support: [Support@RisingHF.com](mailto:Support@RisingHF.com)

Business:

China: [Salescn@RisingHF.com](mailto:Salescn@RisingHF.com)

Others: [Salesww@RisingHF.com](mailto:Salesww@RisingHF.com)

Table 9 Ordering information

Part Number	MCU	434/470MHz TX Power (dBm)	868/915MHz TX Power (dBm)	AT Modem	FW Version	Status
<del>RHF78-052AM</del>	<del>ROM 64KB / RAM 8KB</del>	<del>19</del>	<del>NA</del>	<del>Yes</del>	<del>2.1.19</del>	<del>EOL</del>
RHF78-052AL	ROM 64KB / RAM 8KB	19	NA	Yes	2.1.19	MP
<del>RHF76-052CM</del>	<del>ROM 64KB / RAM 8KB</del>	<del>NA</del>	<del>19</del>	<del>Yes</del>	<del>2.1.19</del>	<del>EOL</del>
RHF76-052CL	ROM 64KB / RAM 8KB	NA	19	Yes	2.1.19	MP
<del>RHF76-052AM</del>	<del>ROM 64KB / RAM 8KB</del>	<del>19</del>	<del>14</del>	<del>Yes</del>	<del>2.1.19</del>	<del>EOL</del>
RHF76-052DM	ROM 128KB / RAM 20KB	19	14	Yes	3.5.13	MP

For more details of the AT command spec, please refer to doc below:

<[RHF-PS01709]LoRaWAN Class ABC AT Command Specification>;

<[RHF-PS01509]LoRaWAN Class AC AT Command Specification>;

<[RHF-AN01700]RisingHF LoRaWAN AT Command Firmware Complete>.

## Revision History

Vo.7 2019-10-10

- + Update the RHF76-052DM FW version to v3.5.13

- + Update the RHF76-052CL/RHF78-052AL FW version to v2.1.19

Vo.6 2017-07-05

- + Update the new part number RHF76-052CL and RHF78-052AL

Vo.1 2016-07-25

- + Creation

## Please Read Carefully:

Information in this document is provided solely in connection with RisingHF products. RisingHF reserve the right to make changes, corrections, modifications or improvements, to this document, and the products and services described herein at any time, without notice.

All RisingHF products are sold pursuant to RisingHF's terms and conditions of sale.

Purchasers are solely responsible for the choice, selection and use of the RisingHF products and services described herein, and RisingHF assumes no liability whatsoever relating to the choice, selection or use of the RisingHF products and services described herein.

No license, express or implied, by estoppel or otherwise, to any intellectual property rights is granted under this document. If any part of this document refers to any third party products or services it shall not be deemed a license grant by RisingHF for the use of such third party products or services, or any intellectual property contained therein or considered as a warranty covering the use in any manner whatsoever of such third party products or services or any intellectual property contained therein.

UNLESS OTHERWISE SET FORTH IN RisingHF'S TERMS AND CONDITIONS OF SALE RisingHF DISCLAIMS ANY EXPRESS OR IMPLIED WARRANTY WITH RESPECT TO THE USE AND/OR SALE OF RisingHF PRODUCTS INCLUDING WITHOUT LIMITATION IMPLIED WARRANTIES OF MERCHANTABILITY, FITNESS FOR A PARTICULAR PURPOSE (AND THEIR EQUIVALENTS UNDER THE LAWS OF ANY JURISDICTION), OR INFRINGEMENT OF ANY PATENT, COPYRIGHT OR OTHER INTELLECTUAL PROPERTY RIGHT.

RISINGHF PRODUCTS ARE NOT DESIGNED OR AUTHORIZED FOR USE IN: (A) SAFETY CRITICAL APPLICATIONS SUCH AS LIFE SUPPORTING, ACTIVE IMPLANTED DEVICES OR SYSTEMS WITH PRODUCT FUNCTIONAL SAFETY REQUIREMENTS; (B) AERONAUTIC APPLICATIONS; (C) AUTOMOTIVE APPLICATIONS OR ENVIRONMENTS, AND/OR (D) AEROSPACE APPLICATIONS OR ENVIRONMENTS. WHERE RISINGHF PRODUCTS ARE NOT DESIGNED FOR SUCH USE, THE PURCHASER SHALL USE PRODUCTS AT PURCHASER'S SOLE RISK, EVEN IF RISINGHF HAS BEEN INFORMED IN WRITING OF SUCH USAGE, UNLESS A PRODUCT IS EXPRESSLY DESIGNATED BY RISINGHF AS BEING INTENDED FOR "AUTOMOTIVE, AUTOMOTIVE SAFETY OR MEDICAL" INDUSTRY DOMAINS ACCORDING TO RISINGHF PRODUCT DESIGN SPECIFICATIONS. PRODUCTS FORMALLY ESCC, QML OR JAN QUALIFIED ARE DEEMED SUITABLE FOR USE IN AEROSPACE BY THE CORRESPONDING GOVERNMENTAL AGENCY.

Resale of RisingHF products with provisions different from the statements and/or technical features set forth in this document shall immediately void any warranty granted by RisingHF for the RisingHF product or service described herein and shall not create or extend in any manner whatsoever, any liability of RisingHF.

RisingHF and the RisingHF logo are trademarks or registered trademarks of RisingHF in various countries.

Information in this document supersedes and replaces all information previously supplied.

The RisingHF logo is a registered trademark of RisingHF. All other names are the property of their respective owners.

© 2015 RisingHF - All rights reserved

<http://www.RisingHF.com>